

Elekta Neuromag® TRIUX

Technical Manual



Document ID:
Publication date:
Language:

NM24132A-B
May 2017
English



Copyright ©2011-2017 Elekta Oy. All rights reserved.

No part of this document may be reproduced in any form without written permission from the copyright holder. Use of the information contained herein is strictly reserved for Elekta and its Licensees. Other use in any form and/or by any means is prohibited.

Elekta Oy makes no warranty of any kind with regard to this document and the related product, including but not limited to, the implied warranties of merchantability and fitness for a particular purpose. Elekta Oy shall not be liable for errors contained herein or direct, indirect, incidental or consequential damages in connection with the furnishing, performance, or use of this material and software.

Elekta Oy reserves the right to make changes in the specifications or data shown herein at any time without notice or obligation.

Elekta Neuromag® and MaxFilter™ are trademarks of Elekta. All other company names and product names are used for identification purposes only, and they may be trademarks or registered trademarks of their respective owners.

This product is protected by the following patents:

US6538436 (Interference suppression)
US6876196 (Head position determination)
US7335838 (Magnetic shielding)
US7463024 (Signal Space Separation)
US7502720 (Signal Space Separation)
US7649351 (Interference suppression)
US7933727 (Interference suppression)
US8229540 (Ac and dc signal separation)
US8253036 (Magnetic shielding)

Manufacturer:

Elekta Oy
Siltasaarekatu 18-20 A
FI-00530 Helsinki, Finland
Tel: +358 9 756 2400
Fax: +358 9 756 24011
Web: www.elekta.com
E-mail: meg-support@elekta.com

Printing history	Neuromag p/n	Date
First edition	NM24132A	04.02.2011
A	NM24132A-A	03.05.2013
B	NM24132A-B	23.05.2017

0537

List of symbols

The following symbols are used in the system and in the manuals. Familiarize yourself with each symbol and its meaning before operating this system.



Caution. Parts of the system are marked with this symbol when it is necessary for the user to draw attention to avoiding a potential hazard or to ensure safe, correct or improved operation and to avoid damage.



Refer to the instruction manual. Parts of the system are marked with this symbol when it is *mandatory* for the user to refer to instructions given in the manuals accompanying the system to in order to ensure safe operation. In the manuals, it also calls attention to these instructions.



Consult instructions for use. Parts of the system are marked with this symbol when it is necessary for the user to refer to instructions given in the manuals accompanying the system. In the manuals, it also calls attention to these instructions. They intend to ensure correct or improved operation and/or increased safety and to avoid damage.



Type BF (body floating) equipment symbol. The applied parts (parts in direct contact with the person being investigated with the system) and the type plate are marked with this symbol to indicate that they fulfill the leakage current requirements of the safety standard IEC 60601-1).



Alternating current (power line) symbol.



Protective ground (earth) terminal symbol. Used to identify terminals which are intended for connection to an external protective conductor for protection against electrical shock in case of a fault, or to the terminal of a protective ground (earth) electrode.



Static electricity symbol. The parts of the system marked with this symbol indicate the presence of components susceptible to static electricity and require the use of special static-electricity preventing techniques.



Non-ionizing radiation, RF transmitter. Marking on equipment or equipment parts that include RF transmitters or that intentionally apply RF electromagnetic energy.



Disposal instruction symbol. Separate collection of waste electrical and electronics equipment (WEEE) necessary (European Union directive 2012/19/EU on WEEE).



Date of manufacture: year (four digits) followed by month and day (if applicable).

Warnings, cautions and notes



WARNING 0.0: Warnings are directions which, if ignored, can constitute a health hazard, cause fatal or serious injury, or lead to erroneous clinical diagnosis and, possibly, to clinical mistreatment.



CAUTION 0.0: Cautions are directions which you must obey to ensure safe and efficient operation and to avoid damage to the system.

Note:

Notes give you advice and recommendations for safe and efficient use of the product as well as highlight unusual points.

1	Technical data	3
1.1	The probe unit	3
1.1.1	General	3
1.1.2	Sensors	3
1.1.3	Probe unit construction	3
1.1.4	Dewar	4
1.2	Patient positioning	4
1.2.1	Gantry	4
1.2.2	Couch	5
1.2.3	Chair	5
1.3	Electronics	5
1.3.1	General	5
1.3.2	MEG preamplifiers	6
1.3.3	Bioamplifiers	6
1.3.4	EEG preamplifiers (optional)	7
1.3.5	Electrode interface	7
1.3.5.1	Electrode interface panel	7
1.3.5.2	Electrode headbox	8
1.3.6	Filter units	8
1.3.6.1	Signal feedthrough filters	8
1.3.6.2	Power feedthrough filter for non-isolated power	8
1.3.6.3	Isolated power feedthrough filter for Bioamplifier, EEG, and HPI channels	8
1.3.6.4	Other feedthrough RF filters	8
1.3.7	Main electronics	9
1.3.7.1	MEG channels	9
1.3.7.2	Bioamplifier, EEG, and analog input main electronics	9
1.4	Power Supplies	10
1.4.1	Front-end non-isolated power supply units	10
1.4.2	Front-end EEG ac power supply (isolated)	10
1.4.3	Main electronics power supply unit	10
1.4.4	Isolation transformers	11
1.5	Filter Unit Cabinet and Electronics Cabinet	11
1.5.1	Filter unit cabinet	11
1.5.2	Main electronics cabinet	11
1.6	Auxiliary electronics	12
1.6.1	Head Position Indicator (HPI)	12
1.6.2	3D digitizer	12
1.6.3	Phantom	12
1.6.4	Liquid Helium level gauge and display	12
1.6.5	Stimulus cabinet	13
1.6.6	Audio electronics interface	13
1.6.7	Thermometer sensors (for maintenance only)	13
1.6.8	Voice intercom (option)	13
1.6.9	Video monitor (option)	14
1.7	Data Acquisition Hardware	14
1.7.1	Stimulus I/O interface	14
1.8	Data acquisition workstation	14
1.9	Helium transfer equipment	15
1.10	Environmental and power requirements, grounding	15
1.11	Classification (IEC 60601-1)	16
1.12	Miscellaneous	16
1.13	Options, accessories, utilities, and consumables	17
1.13.1	Built-to-order options	17
1.13.2	Magnetic shielding	17
1.13.3	Patient positioning	17
1.13.3.1	Patient chair options	17
1.13.4	Stimulators and response recording devices	17

1.13.5	Data analysis	18
1.13.6	Utilities, accessories and other optional add-on modules	18
1.13.7	Consumables	18
1.14	Electromagnetic compatibility (EMC)	19
1.14.1	General	19
1.14.2	List of cables, transducers, and other accessories	19
1.14.3	Guidance and manufacturer's declaration	19
1.15	Final disposal	22
2	Dimensions and weights	25
2.1	Dewar	25
2.2	Probe unit	27
2.3	Electronics cabinets	30
2.4	Miscellaneous	32
2.5	Table of dimensions and weights	33
3	Diagrams	35
3.1	Probe unit	35
3.1.1	Sensor array	35
3.2	Electronics diagrams	36
3.2.1	System diagrams	36
3.2.2	Bioamplifier/EEG electronics	38
3.2.3	Lifting mechanism	39
3.2.4	Audio interface	40
3.3	Powering and grounding	40
3.3.1	Mains connections	40
3.3.2	Main electronics cabinet power distribution	41
3.4	Stimulus cabinet	41
3.5	Networking and data acquisition software	42

1 Technical data

1.1 The probe unit

1.1.1 General

- Number of MEG channels: 306 channels
- Sensor coverage: whole cortex, 1220 cm²
- Measurement positions: supine (0°), reclined seated (60°), upright seated (68°)
- Minimum room height required: 2.3 m
- Dimensions and weights: see chapter 2

1.1.2 Sensors

- Type of sensors: 102 identical plug-in triple-sensor units with two orthogonal planar gradiometer flux transformers, one magnetometer flux transformer, and three dc-SQUIDs (Superconducting Quantum Interference Devices).
- Field components: B_z , $\partial B_z/\partial x$, and $\partial B_z/\partial y$
- Average triple-sensor unit spacing: 35 mm
- Size of gradiometers: 28 mm x 28 mm
- Size of magnetometers: 21 mm x 21 mm
- Type of SQUIDs: dc SQUIDs
- Construction of gradiometers and magnetometers: thin-film structures on silicon
- Base length of gradiometers: 17 mm
- Integrated heater elements for de-trapping.
- Geometrical balance: better than 10^{-3} for gradiometers.
- Noise performances for all operational channels are the following:
- Gradiometer noise (white noise, 60 Hz < f < 70 Hz): max. 5 fT/(cm√Hz) for 96% of channels, max. 10 fT/(cm √Hz) for all gradiometer channels
- Magnetometer noise (white noise, 60 Hz < f < 70 Hz): max. 5 fT/√Hz for 96% of channels, max. 10 √Hz for all magnetometer channels
- Gradiometer noise (low frequency, 1 Hz < f < 10 Hz); max. 12 fT/(cm √Hz) for 96% of channels, max. 20 fT/(cm √Hz) for all gradiometer channels
- Magnetometer noise (low frequency, 1 Hz < f < 10 Hz); max. 12 fT/√Hz for 96% of channels, max. 20 fT/√Hz for all channels

1.1.3 Probe unit construction

- Wiring unit: a flexible support tube and a support shell onto which the triple sensor elements are mounted with connectors, sensor adapter boards.
- Connection wiring: flexible cable assembly from the sensor adapter boards to the top flange
- Top flange: preamplifiers and connectors for the cables to the electronics
- Liquid He-level probe: integrated, superconducting

- Helium siphon: fixed, connects to a flexible part used in transfers
- Thermometers: two Pt-thermometers for monitoring the cool-down and warm-up of the system

1.1.4 Dewar

- Lower end: helmet-shaped
- Circumference of helmet outside surface: 629 mm
- Maximum length of the helmet opening: 222 mm
- Maximum width of the helmet opening: 181 mm
- Maximum inside height of the helmet: 210 mm
- Distance from the surface at liquid helium to the outer room temperature surface against the subject's head: typically 18 mm
- Thermal radiation shielding: superinsulation and a thermally anchored shield
- Material of construction: fiberglass composite
- Total volume of liquid Helium 78 liters
- Refill interval of liquid Helium: 7 days
- Exhaust of Helium gas due to liquid Helium boiloff (+20 °C, normal operation at atmospheric pressure): typ. 4 liters per minute
- Helium transfer equipment: see chapter 1.9 below
- Monitoring of the liquid Helium level: integrated sensor and readout electronics
- Separate local liquid Helium level display integrated inside the gantry for follow-up during the transfer
- Automatic helium level data gathering to the data acquisition workstation
- Relief valve opening pressure: approx. 10 kPa (0.1 bar)
- Safety exhaust membrane rupture pressure: approx. 60 kPa (0.6 bar)
- Safety exhaust duct diameter: 60 mm

1.2 Patient positioning

1.2.1 Gantry

- Principal material of construction: fiberglass composite
- Measurement positions: supine (helmet horizontal), reclined seated (helmet tilted 60° from horizontal), upright seated (helmet tilted 68° from horizontal)
- Liquefaction position (when internal helium recycler is in use): helmet tilted 25° from horizontal
- User controlled up- and down-buttons and manual latch bar for controlling gantry movements between gantry positions
- Movement mechanism: motor-driven rope, controlled by push-buttons at gantry. Positions secured by safety latches at seated and liquefaction positions and mechanical stoppers at supine position. Motor located outside the magnetically shielded room. Position indicator display inside the magnetically shielded room.
- Mains input: 230 V~ 47–63 Hz. Separate portable step-up transformer, 100 V or 120 V 1.2 kVA, if necessary

- Dimensions and weights: see chapter 2
- Side panel with connectors of auxiliary electronics, bioamplifier, and EEG
- Cover of the refill opening including a plug for the fixed siphon and local liquid Helium level display

1.2.2 Couch

- Principal material of construction: fiberglass composite
- Method of operation: manual, mechanical
- Movement of couch: front/back, turning wheels
- Movement of upper bed: front/back
- Movement mechanism: Push/pull by hand. Wheels and upper part provided with locks.
- Removable head support
- Removable side guards
- Safety belt
- Movement range of the upper bed: approx. 250 mm
- 135 kg maximum load
- Dimensions and weights: see chapter 2.

1.2.3 Chair

- Principal material of construction: fiberglass composite
- Method of operation: manual, mechanical, hydraulic
- Movement of chair: front/back; movement of seat: up/down. With chair fine-adjustment option, movement of backrest; reclined/upright.
- Horizontal movement mechanism: chair on wheels, push/pull by hand using a handle. With chair fine-adjustment option, horizontal movement mechanism: hydraulic. Chair provided with brake.
- Vertical movement mechanism: Elevation pedal to raise the seat, release pedal to lower the seat.
- Up/down movement range: approx. 300 mm
- Legrests that can be elevated
- Two removable table plates with non-slip table top
- 135 kg maximum load
- Dimensions and weights: see chapter 2.

1.3 Electronics

1.3.1 General

The electronics comprises 306 MEG channels, 12 bioamplifier channels, and, optionally, 32, 64, or 128 EEG channels as well as auxiliary electronics (see section 1.6). The electronics can be divided in the following blocks:

- Preamplifiers inside of the probe unit, including a built-in interface for bioamplifiers, EEG channels, and auxiliary electronics
- Feedthrough RF filters/Optoisolators (bioamplifiers and EEG channels) inside the filter unit
- Main electronics racks inside the main electronics cabinet
- Power supplies

For block diagrams and schematic diagrams see Chapter 3.

1.3.2 MEG preamplifiers

- Preamplifiers for MEG channels inside the magnetically shielded room on the Dewar top flange.
- SQUID tuning:automatic/manually
- 12 channels on each preamplifier board, connected to a preamplifier motherboard on top of the Dewar top flange
- Flux locked loop operation, controller on main electronics board
- MEG preamplifier based on direct readout and amplifier noise cancellation
- Integrated heater (detrapping) control in preamplifiers
- Control bus for setting the operating points of the front-end electronics, driven by fiber optic link from the main electronics cabinet
- User-controlled parameters: bias, offset, and amplifier noise cancellation
- No digital operations during measurement
- Powered by power supplies inside the main electronics cabinet via power feedthrough unit

1.3.3 Bioamplifiers

- 12 channels, all channels having differential input (also referred as bipolar)
- Noise < 0.4 μVrms (0.5 – 100 Hz), measured with a 10 k Ω impedance across the input
- Input impedance at dc > 100 M Ω
- Software-controlled gain of the preamplifier (approximately 30/100/1000), selectable individually for each channel. The optoisolation/feedthrough filter (see 1.3.6) has an additional fixed gain of 20, making the total gain approx. 600/2000/20000.
- Common-mode rejection ratio 100 dB (with active ground)
- Test oscillator for testing the channels, recording calibration signal and for measuring the electrode impedances
- Test oscillator frequency and amplitude set by data acquisition software. Currently used calibration signal $\pm 100 \mu\text{V}$ square wave at 1 Hz.
- Analog high-pass filter cut-offs dc / 0.03 Hz / 0.1 Hz / 10 Hz (–3 dB corner frequency), selectable individually for each channel by software
- Low-pass filtering by data acquisition software
- In dc mode, largest input offset that can be compensated for is $\pm 100 \text{ mV}$
- Leakage currents comply with class BF (body floating) devices according to IEC60601-1
- Buffered reference input channel for active grounding and for unipolar EEG
- Active grounding (at frequencies greater than 5 Hz) for increased common-mode rejection

- Unused (unselected) channels deactivated by software: electrode inputs decoupled, amplifier inputs and outputs clamped
- No digital operations during measurement
- Powered by an isolated power supply

1.3.4 EEG preamplifiers (optional)

- 16 channels/board, all channels having internal differential inputs
- 32, 64, or 128 channels
- Common reference from reference channel at bioamplifier
- Bioamplifiers and EEG channels accommodated by a single subrack
- Noise < 0.4 μV_{rms} (0.5 – 100 Hz), measured with a 10 k Ω impedance across the input
- Input impedance at dc > 100 M Ω
- Software-controlled gain of the preamplifier (approximately 30/100/1000), selectable individually for each channel. The optoisolation/feedthrough filter (see 1.3.6) has an additional fixed gain of 20, making the total gain approx. 600/2000/20000.
- Common-mode rejection ratio 100 dB (with active ground)
- Test oscillator for testing the channels, recording calibration signal and for measuring the electrode impedances
- Test oscillator frequency and amplitude set by data acquisition software. Currently used calibration signal $\pm 100 \mu\text{V}$ square wave at 1 Hz.
- Analog high-pass filter cut-offs dc / 0.03 Hz / 0.1 Hz / 10 Hz (–3 dB corner frequency), selectable individually for each channel by software
- Low-pass filtering by data acquisition software
- In dc mode, largest input offset that can be compensated for is $\pm 100 \text{ mV}$
- Leakage currents comply with class BF (body floating) devices according to IEC60601-1
- Unused (unselected) channels deactivated by software: electrode inputs decoupled, amplifier inputs and outputs clamped
- No digital operations during measurement
- Powered from an isolated power supply

1.3.5 Electrode interface

1.3.5.1 Electrode interface panel

- On the side panel of the gantry
- Electrode connectors for bioamplifiers, reference electrode (REF), and ground driver (GND), using 1.5-mm touch-proof DIN 42802 connectors
- 32-pin connectors for electrode caps (up to four, depending on the number of EEG channels installed)

1.3.5.2 Electrode headbox

- 32 unipolar channels for single electrodes
- Passive
- 32-pin connector for cable to electrode interface panel in gantry

1.3.6 Filter units

1.3.6.1 Signal feedthrough filters

- 2x12 MEG channels / board
- MEG channels bidirectional (preamplifier output / flux-locked loop feedback)
- Dc coupled
- RF cut-off frequency (– 3 dB point) approx. 140 kHz
- Optoisolation for bioamplifier, EEG, and HPI channels, dielectric strength > 4 kV (according to IEC60601-1, Class B), applied part side powered from an isolated power supply
- 12 bioamplifier and HPI channels / board, 2x16 EEG channels / board
- Bioamplifier and EEG filter fixed gain of 20

1.3.6.2 Power feedthrough filter for non-isolated power

- Power feedthrough for the MEG preamplifiers ($\pm 15\text{ V}$, $\pm 6\text{ V}$, + 5V from frontend power supply)

1.3.6.3 Isolated power feedthrough filter for Bioamplifier, EEG, and HPI channels

- Powered from a 24 V~ ac supply in main electronics cabinet
- Applied part isolated with sector-wound transformer (24 V~/2 x 16 V~), dielectric strength > 4 kV (according to IEC60601-1, Class B)
- Output $\pm 12\text{ V}$, max. +3 A / –1.5 A
- Number of units: 1 (without EEG) / 2 (with EEG)
- RF feedthrough filters in non-isolated circuit

1.3.6.4 Other feedthrough RF filters

- RF feedthrough filter for audio interface
- RF feedthrough filter for Internal Active Shielding, similar to MEG filter unit
- Lifting mechanism control unit and position indicator/ RF filter feedthrough unit

1.3.7 Main electronics

1.3.7.1 MEG channels

- Principle: digital flux-locked feedback control loop realized with a digital signal processor (DSP)
- SQUID Controller Unit (SQC) for 12 channels
- One digital signal processor (DSP) per SQC
- Resolution: 24 bits/sample.
- DC coupled
- High-pass cutoff with DSP software (predefined values DC – 10 Hz)
- Low-pass filter type: 6th order Butterworth IIR filter via DSP
- Cutoff of low-pass filter: predefined values 330 Hz – 1,6 kHz, limited by software to maximum one-third of sampling rate
- Connected over dedicated Ethernet to data acquisition workstation.
- SQC boards also connected with each other over proprietary synchronous backplane bus used for Internal Active Shielding
- Internal Active Shielding backplane signalling bandwidth dc–100 Hz
- Number of subtracks: 2
- Number of SQC boards: 27 (MEG) + additional 2 boards for HPI signals and Internal Active Shielding
- System Controller Board (SCC) for timing, backplane bus control and stimulus trigger input/output (fiber-optical link)
- Trigger event identification: 2 x 16 channels in/out (digital)
- Triggers generated internally by the digital I/O interface included in the data acquisition unit or generated by an external stimulator and acquired via the digital I/O interface.
- Number of System Control Card (SCC) units: 1
- Front End Controller Board for controlling MEG, Bioamplifier and HPI front end (fiber-optical link)
- Located outside of the magnetically shielded room inside a rf-shielded cabinet (main electronics cabinet).
- Powering: Separate power supply for each set of four slots inside the rf-shielded cabinet
- Fan units: mains operated

1.3.7.2 Bioamplifier, EEG, and analog input main electronics:

- Signal acquisition module (SAM) for 12 channels
- one digital signal processor (DSP) per SAM
- Resolution: 16 bits
- Type of coupling: dc
- Input stage realized with instrumentation amplifiers with software controlled gain of 1 or 10, corresponding to SAM input ranges of ± 10 V or ± 1 V, respectively
- All conversions started simultaneously and synchronously with MEG channels
- Low-pass filters identical to those in MEG channels (DSP-based)
- Connected over dedicated Ethernet to data acquisition workstation.

- Number of SAM boards: 2 (bioamplifier and analog input only) plus optionally additional 3 (32 EEG channels) / 6 (64 EEG channels) / 12 (128 EEG channels)
- SAM boards (2) for bioamplifiers and analog input reside in the MEG main electronics rack, optional SAM boards for EEG channels in a separate EEG rack inside the main electronics cabinet
- Powering: Separate power supply for each set of four slots inside the main electronics cabinet
- Fan unit: mains operated.

1.4 Power Supplies

1.4.1 Front-end non-isolated power supply units

- Power rating: 145 W
- Mains: 230 V~, 47...63 Hz, from a dedicated isolation transformer
- Control: manual power switch in cabinet control panel
- Number of units: 7 (MEG) + 1 (non isolated circuits of optoisolators)
- Output: ± 15.5 V = 0.8 A (analog), +6.6 V = 1.2A, -6.6 V = 1.6 A (analog), 5 V = 4 A (digital)
- Output cabling: internal, directly to backplane
- Primary fuses: 230 V 0.63 A slow blow
- Overload and over-temperature protection, undervoltage indication
- Status indicators
- Fan unit: external, permanently mounted in cabinet
- Location: inside main electronics cabinet, integrated to the MEG or EEG subracks

1.4.2 Front-end EEG ac power supply (isolated)

- Output 24 V~
- Mains: 230 V~, 47...63 Hz, from a dedicated isolation transformer
- Primary fuses: 230 V 0.63 A slow blow
- Secondary fuse 5.0 A fast
- Output indicator
- Number of units: 1(bioamplifier and HPI only) / 2 (with optional EEG)
- Location: inside the main electronics cabinet

1.4.3 Main electronics power supply unit

- Power rating: 145 W
- Mains: 230 V~, 47...63 Hz, from a dedicated isolation transformer
- Control: manual power switch in cabinet control panel
- Number of units: 8 (MEG, HPI, bioamplifiers, Internal Active Shielding, analog input, controllers) + optionally additional 1 (32 channel EEG) / 2 (64 channel EEG) / 3 (128 channel EEG)

- Output: ± 15.5 V= 0.8 A (analog), +6.6 V= 1.2A, -6.6 V= 1.6 A (analog), 5 V= 4 A (digital)
- Output cabling: internal, directly to backplane
- Primary fuses: 230 V 0.63 A slow blow
- Overload and over-temperature protection, undervoltage indication
- Status indicators
- Fan unit: external, permanently mounted in cabinet
- Location: inside main electronics cabinet, integrated to the MEG or EEG subracks

1.4.4 Isolation transformers

- Number of units: 3 (MEG, Stimulus, 3D digitizer)
- Primary: 100 / 115 / 120 / 200 / 230 / 240 V~ 50/60 Hz
- Secondary: 230 V~. For stimulus cabinet same as primary.
- Power rating: 2 kVA (MEG), 10 A 100 V / 115 V / 120 V / 200 V / 230 V / 240 V (stimulus), 350 VA 100-240 V / 650 VA 220-240 V (3D digitizer)
- Safety isolating, approved for medical electrical equipment
- Permanent installation of MEG and stimulus cabinet transformers
- Primary fuses: in main electricity distribution panel of the building (customer's responsibility). Recommendation 16 A D-type (200/230/240 V), 25 A D-type (100/115/120 V) for MEG transformer, 16 A D-type for stimulus transformer (all voltages)

1.5 Filter Unit Cabinet and Electronics Cabinet

1.5.1 Filter unit cabinet

- Maximum signal levels to any feedthrough input/output: ± 15 V
- Dimensions and weights: see chapter 2

1.5.2 Main electronics cabinet

- Cabinet type: Schroff HF1
- Cabinet RF attenuation: -90 dB @ 30 MHz, -70 dB @ 300 MHz, -50 dB @ 1 GHz
- RF mains filter: 12 A 250 V~ dual filter (L,N)
- Mains distribution unit with manual circuit breakers for subsystems
- Power failure release switch with thermal overcurrent protection (10 A)
- Filtered power outlets inside cabinet, max. current: 10 A in total
- Mains power: via a dedicated isolation transformer (see 1.4.4) and harmonic filter, permanent installation
- Cooling: forced convection, air flow from base plate (dust filtered) to top cover (equipped with temperature-controlled fans)
- Dimensions and weights: see chapter 2

1.6 Auxiliary electronics

1.6.1 Head Position Indicator (HPI)

- Method: marker coils are attached to the head of the subject
- Excitation: DSP-controlled current drive for each HPI-coil, optically isolated
- Detection of signals: by sensor array
- Number of coils: 5 permanently attached to a connector.
- Drive from HPI/Phantom interface board located in the bioamplifier/EEG preamplifier rack
- Coil current software controlled, typ. 70 μ A
- Coil size: \varnothing 7 mm, thickness 2 mm
- Coils insulated (BF type, dielectric strength 1500 V)
- Determination of position of the marker coils with respect to a subject frame of reference: 3D digitizer included in the system, see 1.6.2.

1.6.2 3D digitizer

- Polhemus Fastrak electromagnetic digitizer including transmitter and stylus receiver
- Specifications: see Polhemus Fastrak User's Manual
- Non-magnetic goggles with an additional receiver for movement correction
- Separate portable medical isolation transformer (see 1.4.4)
- Power requirement 85 – 264 V~, 47 – 63 Hz
- Connected to data acquisition workstation over optically isolated serial line
- Location: in operator area
- Leakage currents of stylus and goggles comply with class BF (body floating) devices according to IEC60601-1, provided that the unit is powered via the portable isolation transformer

1.6.3 Phantom

- Method: line current elements (current dipoles) in spherical geometry
- Length of line current elements: 5 mm
- Radius of curvature: 89 mm
- Number of dipoles: 32
- Number of integrated head position indicator coils: 4
- Connected to the HPI/ phantom interface via the side panel of the gantry
- One dipole active at a time
- Phantom driver (located in bioamplifier/EEG preamplifier rack) transconductance 1.8 mS
- Drive current software controlled, max. \pm 18 mA

1.6.4 Liquid Helium level gauge and display

- Readout: remotely by data acquisition workstation or manually over local display
- Probe active length (nominal): 55 cm

- Probe resistance (nominal, at 300 K): 300 Ω
- Probe resistance (nominal, at 10 K): 250 Ω
- Local display on liquid Helium filling port of the gantry: on/off button, display 0 – 100%

1.6.5 Stimulus cabinet

- Cabinet type: Schroff HF1
- Cabinet RF attenuation: -90 dB @ 30 MHz, -70 dB @ 300 MHz, -50 dB @ 1 GHz
- mains line RF filter: 10 A 250 V max. dual filter (L, N)
- Installation of the mains line RF filter: permanent
- Filtered power outlets inside cabinet: 6, manual circuit breaker with indicator light
- Max. current of the outlet sockets: 10 A in total
- Mains power: via an isolation transformer (see 1.4.4), permanently installed
- Auxiliary feedthrough filters: BNC 1-2, XLR NC connectors 1-2: 20 dB/decade above 20 kHz, feedthrough resistance 7 Ω ; BNC 3-5, XLR NC connector 3: -20 dB @ 10 MHz, -65 dB @ 100 MHz, feedthrough resistance < 1 Ω .
- Maximum signal input/output level to any feedthrough: ± 15 V. Note that the actual value depends on instrument connected by the user to the feedthrough inside the cabinet.
- Cooling: free convection, air flow from base plate (dust filtered) to top cover
- Dimensions and weights: see chapter 2

1.6.6 Audio electronics interface

- Earphone output connector for patient and assistant
- Feedthrough RF filter for audio stimulus signals and microphone
- Microphone input connector for voice intercom

1.6.7 Thermometer sensors (for maintenance only)

- Number: 2
- Locations: lower end of helmet, upper end of wiring unit
- Type: Pt-resistor
- Nominal resistance at 273 K: 100 Ω

1.6.8 Voice intercom (option)

- Desk Unit on operator's table
- Main unit connected to a microphone inside probe unit and to a loudspeaker outside of the magnetically shielded room
- Connect / disconnect
- Automatic control of speech direction
- Manual control of speech direction selectable
- Muting of operator microphone

1.6.9 Video monitor (option)

- Rf-shielded color camera mounted on magnetically shielded room wall
- Color monitor

1.7 Data Acquisition Hardware

1.7.1 Stimulus I/O interface

- Two stimulus I/O interface units, each unit 16 channels
- The units can be operated either in parallel duplicating the input/output at two physically separate places (16 lines total, default mode) or separately (32 lines total, optional)
- Internal trigger line generation to 16 lines
- The trigger lines are optically isolated and synchronized to the MEG/EEG sampling
- MEG/EEG signal delay to trigger signals due to filters max. 3 ms (fixed, depending on MEG/EEG low-pass filter corner frequency). If more accurate timing is needed, the delay must be determined experimentally for the actually used low-pass filter setting

Stimulus input:

- Input pulse level: TTL (+ 5 V high, 0 V low), trigger on rising or falling edge (each channel individually user-configurable).
- Each input has a user-selectable pull-up for connection of passive switches
- Absolute maximum ratings for input voltage: $-0.5\text{ V} \dots +5.5\text{ V}$
- Input impedance: $1\text{ M}\Omega$ (without pull-up)
- Pull-up loop current $500\text{ }\mu\text{A}$
- Input mode: single-ended. Optically isolated from main electronics.
- Delay from interface unit to trigger acquisition less than $50\text{ }\mu\text{s}$
- Minimum detectable pulse length $50\text{ }\mu\text{s}$

Stimulus output:

- Pulse level: TTL (+ 5 V high, 0 V low), rising or falling edge (each channel individually user-configurable)
- Pulse width: typ. 10 ms
- Pulse rate: adjustable from data acquisition program
- Maximum output current: 25 mA
- Output mode: single-ended. Optically isolated from main electronics
- Delay from trigger generation to interface unit less than $50\text{ }\mu\text{s}$
- Pulse length determined in acquisition program (minimum 5 ms)

Input power:

- $+8 \dots 12\text{ V}$, 100 mA. Double-insulated separate supply.

1.8 Data acquisition workstation

- Continuous acquisition time: 8 hours with 306 MEG and 64 EEG channels at 5 kHz sampling rate.
- High-end workstation with a 30" monitor

- CD/DVD+RW drive
- Elekta Linux Distribution operating system
- Elekta Neuromag Data Acquisition Software
- Backup device: DVD-writer, optional DLT backup included in scalable storage server (option)
- Expandability: additional analysis workstations
- Magnetic resonance image (MRI) importing: DICOM 3.0
- Hardcopy devices (optional): color laser printer
- Dedicated optical ethernet connection to the main electronics abinet

1.9 Helium transfer equipment

- From standard storage Dewar with flexible siphon, connecting to integral fixed siphon part in the probe unit
- Flexible siphon
- 2 filter cartridges
- Flexible siphon extension tube
- Cryogenic accessory kit
- Transfer exhaust hose (silicon) with hose clamp
- Manual pressurizing unit

1.10 Environmental and power requirements, grounding

- Temperature during operation (performance guaranteed): +20°C...+24°C
- Temperature during operation (performance not guaranteed, IEC 60601-1 requirements fulfilled): +10°C...+40°C
- Temperature during storage and transport: +0°C...+40°C
- Relative humidity during operation (performance guaranteed): 40%...70% RH, non-condensing
- Relative humidity during operation (performance not guaranteed, IEC 60601-1 requirements fulfilled): 30%...75% RH, non-condensing
- Relative humidity during storage and transport: 10%...95% RH, non-condensing. Special packaging instructions must be obeyed (available from Elekta).
- Maximum operating altitude: 2000 m
- Mains power voltage: 100/115/200/230/240 V~ ± 10 %
- Mains frequency: 47...63 Hz

Table 1.1 Power consumption of system units. The total consumption depends on system configuration.

Unit	Power [W]	Appar. [VA]	Notes
Main electronics cabinet	1900	2000	128 ch EEG
Lifting unit	10/750	20/1200	Idle/working (20 s / run)
3-D digitizer	40	60	

Table 1.1 Power consumption of system units. The total consumption depends on system configuration.

Unit	Power [W]	Appar. [VA]	Notes
Acquisition workstation, TFT monitor (typ.)	400		
Analysis workstation, TFT monitor (typ.)	400		
Trigger I/O unit (2 pcs, total)	20		
Voice intercom (typ.)	10		
CCTV video monitoring (typ.)	50		
Finger response pad	10		
Color printer (typ.)	250/1650		Norm./max.
Video projector (typ.)	800		
Electrical stimulator (typ.)	10		
Audiovisual stimulus system (typ.)	200		
Data storage platform (typ.)	2000		
External active shielding (typ.)	200		
Magnetically shielded room lights (typ.)	400		
<p>Note 1: Stimulus cabinet not included as a unit since the consumption depends on the equipment used. Max 10 A</p> <p>Note 2: Ratings marked with “typ.” are representative values only, actual values depend on the exact model and configuration used</p> <p>Note 3: Internal active shielding included in the main electronics cabinet</p> <p>Note 2: Optional data storage units, lighting outside the shielded room, air conditioning and general purpose outlets not included</p>			

- Power consumption of whole system depends on system configuration, see Table 1
- Connection of the main electronics cabinet and stimulator cabinet to mains via separate isolation transformers, see Fig. 3.11 and 1.4.5.
- Grounding: magnetically shielded room, main electronics cabinet, and stimulator cabinet permanently grounded at a single point, see Fig. 3.7.

1.11 Classification (IEC 60601-1)

Classification according to IEC 60601-1:

- Class I equipment
- BF-type equipment

1.12 Miscellaneous

- Disinfection of applied parts: absolute (>96%) alcohol
- Cleaning of non-applied parts: see Elekta Neuromag® TRIUX *User’s Manual*
- Mode of operation: continuous

1.13 Options, accessories, utilities, and consumables

This section lists options, accessories, utilities, and consumables expressly recognized as compatible with Elekta Neuromag® TRIUX.

1.13.1 Built-to-order options

- 32-channel EEG system (NM23904N)
- 64-channel EEG system (NM23889N)
- 128-channel EEG system (NM23893N)

1.13.2 Magnetic shielding

- MaxShield™ single-layer magnetic shield (NM23009N)
- Two-layer magnetic shield (NM23122N)
- External active shielding system (NM23040N)

Note: *The type of magnetic shielding required is determined as a part of site planning after a magnetic site survey (mandatory) has been made by Elekta. The compatibility of other magnetically shielded rooms (e.g., already existing rooms on site) is assessed as a part of this process.*

1.13.3 Patient positioning

- Patient couch (NM23125N)
- Patient chair (NM23124N)

1.13.3.1 Patient chair options

- Chair fine-adjustment system (NM25745N)
- Pediatric comfort set (NM25744N)

1.13.4 Stimulators and response recording devices

- Audiovisual stimulus presentation system (NM21711N)
- Somatosensory stimulator (NM21709N)
- High-fidelity visual stimulator (NM24034N)
- Auditory stimulator (NM24035N)
- Bilateral finger response system (NM2099N)
- Eye-tracking system (NM23399N; *Not for clinical use, only for research*)
- Projector mirror system (left-handed NM23386N, right-handed NM23837N)
- Mirror system for supine position (GA24646K)
- 128-channel EEG head box (NM24332N)

1.13.5 Data analysis

- Data analysis workstation (NM20998N)
- Data analysis software, single node license (NM23321N)
- Data analysis software, site license (NM23326N)

1.13.6 Utilities, accessories and other optional add-on modules

- Bidirectional voice intercommunication system (NM21632N)
- Video monitoring system (NM21712N)
- Colour printer (NM23131N)
- Scalable storage server (NM23132N)
- High-capacity tape library (NM23133N)
- Storage module (NM23134N)
- Acquisition system Uninterruptible Power Supply (NM24062N)
- Workstation Uninterruptible Power Supply (NM24063N)
- Helium pressurizing unit (HE23609N)
- Standalone helium liquefier interface (NM24826N)
- Visual stimulus calibration unit (NM24455N)
- Oxygen level monitor (NM25611N)

1.13.7 Consumables

- Head position coil set (NM23880N)
- Small-size 32-channel EEG cap (NM23905N)
- Medium-size 32-channel EEG cap (NM23906N)
- Large-size 32-channel EEG cap (NM23907N)
- Small-size 64-channel EEG cap (NM23890N)
- Medium-size 64-channel EEG cap (NM23891N)
- Large-size 64-channel EEG cap (NM23892N)
- Small-size 128-channel EEG cap (NM23894N)
- Medium-size 128-channel EEG cap (NM23895N)
- Large-size 128-channel EEG cap (NM23896N)
- Headrest paper cover (961042)
- Replacement felt tip (961460)
- Single-use electrode (968508)

1.14 Electromagnetic compatibility (EMC)

1.14.1 General

Parts of Elekta Neuromag® TRIUX (the probe unit) must be permanently installed inside a magnetically shielded room. Prior to installation, a magnetic site survey and determination of necessary magnetic shielding must be performed for each installation site as a normal part of the site planning. The magnetic shield also comprises an RF shield. The electronics cabinets with the dedicated feedthroughs to the magnetically shielded room must be properly installed by authorized personnel. Such combination of the magnetically shielded room and Elekta Neuromag® TRIUX must be always be considered together as an entity.

The magnetically shielded room should have a minimum RF shielding effectiveness and, for each cable that exits the shielded location, a minimum RF filter attenuation of 40 dB from 1 MHz to 1000 MHz.

Note: *The exemption specified in IEC 60601-1-2, clause 36.202.3 b 9, regarding large permanently installed systems has been used. The system has not been tested for radiated RF immunity over the entire frequency range 80 MHz to 2.5 GHz. The system has been tested of RF immunity only at selected frequencies using conducted RF current-injected from an RF generator whose output is 80 % amplitude modulated at 2 Hz in the frequency range 150 kHz – 220 MHz.*

1.14.2 List of cables, transducers, and other accessories

External cables connected to the magnetically shielded room and to the electronics cabinets may affect electromagnetic compatibility. They comprise:

- Mains power cables of main electronics cabinet and stimulus cabinet (three-wire mains cable, length 20 m)
- Lifting unit motor control cable (twisted pair, length 8 m)
- Audio stimulus cables (shielded twisted pairs, length 10 m)
- Polhemus Fastrak system with transmitter (cable length 3 m), stylus receiver(cable length 3 m), and goggle receiver (cable length 3 m),
- Microphone cable (shielded twisted pair, length 5 m), loudspeaker cable (shielded twisted pair, length 5 m), and connection cable (twisted pair, length 10 m) for voice intercom option
- Analog input cable (twisted pair, length 7.5 m)

Note: *The use of accessories, transducers, and cables other than those specified, with the exception of accessories, transducers, and cables sold by the manufacturer of the system as replacement parts for internal components, may result in increased emissions or decreased immunity of the system.*

1.14.3 Guidance and manufacturer's declaration

Note: *Elekta Neuromag® TRIUX should not be used adjacent to other systems, and if adjacent operation is necessary, the system should be observed to verify normal operation in the configuration in which it will be used.*

Note: *Elekta Neuromag® TRIUX should be permanently installed together with magnetically shielded room, see 1.14.1. It is essential that the actual RF shielding effectiveness and filter attenuation of the shielded location be verified to ensure that they meet or exceed the specified minimum values.*

Note: *Inside the magnetically shielded room, the use of devices radiating RF energy such as portable and mobile RF communications equipment such as mobile phones is prohibited. Use of other equipment except accessories and options supplied with the system should be avoided; only equipment verified not to affect system performance may be used. A notice concerning this should be posted at the entrance of the magnetically shielded room.*

Elekta Neuromag® TRIUX is intended for use only in the electromagnetic environment specified below. The customer or the user of Elekta Neuromag® TRIUX should assure that it is used in such an environment.

Table 1.2 *Guidance and manufacturer's declaration - electromagnetic emissions*

Emissions test	Compliance	Electromagnetic environment - guidance
RF emissions CISPR 11	Group 1	Elekta Neuromag® TRIUX uses RF energy only for its internal function. Therefore, its RF emissions are very low and are not likely to cause any interference in nearby electronic equipment.
RF emissions CISPR 11	Class B / A	Elekta Neuromag® TRIUX, when installed properly as described in 1.14.1 is suitable for use in all establishments other than domestic and those directly connected to the public low-voltage network that supplies buildings used for domestic purposes. Class A applies for systems connected to the mains via an uninterruptible power supply.
Harmonic emissions IEC61000-3-2	Not applicable	
Voltage fluctuations / flicker emissions IEC61000-3-3	Not applicable	

The Elekta Neuromag® TRIUX is intended for use in electromagnetic environment specified below. The customer user of Elekta Neuromag® TRIUX should assure that it is used in such an environment.

Table 1.3 *Guidance and manufacturer's declaration - electromagnetic immunity*

Immunity test	IEC 60601 test level	Compliance level	Electromagnetic environment – guidance
Electrostatic discharge (ESD) IEC 61000-4-2	± 6 kV contact ± 6 kV air	± 6 kV contact ± 8 kV air	Floors should be wood, concrete or ceramic tile. If floors are covered with synthetic material, the relative humidity should be at least 30 %. An ESD preventing floor covering is recommended.
Electrical fast transients / burst IEC 61000-4-4	± 2 kV for power supply lines ± 1 kV for input/output lines	± 2 kV for power supply lines ± 1 kV for input/output lines	Mains power quality should be that of a typical commercial or hospital environment.
Surge IEC 61000-4-5	± 1 kV differential mode ± 2 kV common mode	± 1 kV differential mode ± 2 kV common mode	Mains power quality should be that of a typical commercial or hospital environment.

Table 1.3 Guidance and manufacturer's declaration - electromagnetic immunity

Immunity test	IEC 60601 test level	Compliance level	Electromagnetic environment – guidance
<p>Conducted RF IEC 61000-4-6</p> <p>Radiated RF IEC 61000-4-6</p>	<p>3 Vrms 150 kHz to 80 MHz</p> <p>3 V/m 80 MHz to 2.5 GHz</p>	<p>3 V</p> <p>3 V/m</p>	<p>Portable and mobile RF communications equipment should be used no closer to any part of Elekta Neuromag® TRIUX combined with the magnetically shielded room (see 1.14.1), including cables, than the recommended separation distance calculated from the equation applicable to the frequency of the transmitter.</p> <p>Recommended separation distance</p> $d = 1.2\sqrt{P}$ <p>$d = 1.2\sqrt{P}$ 80 MHz to 800 MHz $d = 2.3\sqrt{P}$ 800 MHz to 2.5 GHz</p> <p>where P is the maximum output power rating of the transmitter in Watts (W) according to the transmitter manufacturer and d is the recommended separation distance in metres (m).</p> <p>Field strengths from fixed RF transmitters, as determined by an electromagnetic site survey,^a should be less than the compliance level in each frequency range.^b</p> <p>Interference may occur in the vicinity of equipment marked with the following symbol:</p> 
<p>Voltage dips, short interruptions and voltage variations on power supply input lines IEC 61000-4-11</p>	<p>Not applicable</p>	<p>Not applicable</p>	<p>Mains power quality should be that of a typical commercial or hospital environment. The system is equipped with no-voltage mains release switch; after mains interruption a normal power-up sequence by the operator is necessary. If the user of Elekta Neuromag® TRIUX requires continued operation during power mains interruptions, it is recommended that Elekta Neuromag® TRIUX be powered from an uninterruptible power supply.</p>
<p>Power frequency (50/60 Hz) magnetic field IEC 61000-4-8</p>	<p>Not applicable</p>	<p>Not applicable</p>	<p>The product is intended to measure magnetic fields at a very low level in a frequency range that includes 50/60 Hz. A magnetic site survey and adjacent determination of necessary magnetic shielding must be performed for each installation site prior to installation as a normal part of the site planning.</p>

Table 1.3 Guidance and manufacturer's declaration - electromagnetic immunity

Immunity test	IEC 60601 test level	Compliance level	Electromagnetic environment – guidance
NOTE 1 At 80 MHz and 800 MHz, the higher frequency range applies.			
NOTE 2 These guidelines may not apply in all situations. Electromagnetic propagation is affected by absorption and reflection from structures, objects and people.			
<p>^a Field strengths from fixed transmitters, such as base stations for radio (cellular/cordless) telephones and land mobile radios, amateur radio, AM and FM radio broadcast and TV broadcast cannot be predicted theoretically with accuracy. To assess the electromagnetic environment due to fixed RF transmitters, an electromagnetic site survey should be considered. If the measured field strength in the location in which Elekta Neuromag® TRIUX is used exceeds the applicable RF compliance level above, Elekta Neuromag® TRIUX should be observed to verify normal operation. If abnormal performance is observed, additional measures may be necessary, such as reorienting or relocating Elekta Neuromag® TRIUX.</p> <p>^b Over the frequency range 150 kHz to 80 MHz, field strengths should be less than 3 V/m.</p>			

Elekta Neuromag® TRIUX is intended for use in electromagnetic environment in which radiated RF disturbances are controlled. The customer user of Elekta Neuromag® TRIUX can help prevent electromagnetic interference by maintaining a minimum distance between portable and mobile communications equipment (transmitters) and Elekta Neuromag® TRIUX as recommended below, according to the maximum output power of the communications equipment.

Table 1.4 Recommended separation distances between portable and mobile RF communications equipment and Elekta Neuromag® TRIUX

Rated maximum output power of transmitter [W]	Separation distance according to frequency of transmitter [m]		
	150 kHz to 80 MHz $1.2\sqrt{P}$	80 MHz to 800 MHz $1.2\sqrt{P}$	800 MHz to 2,5 GHz $2.3\sqrt{P}$
0.01	0.12	0.12	0.23
0.1	0.38	0.38	0.73
1	1.2	1.2	2.3
10	3.8	3.8	7.3
100	12	12	23
<p>For transmitters rated at a maximum output power not listed above, the recommended separation distance <i>d</i> in metres (m) can be estimated using the equation applicable to the frequency of the transmitter, where <i>P</i> is the maximum output power rating of the transmitter in watts (W) according to the transmitter manufacturer.</p> <p>Note 1: At 80 MHz and 800 MHz, the separation distance for the higher frequency range applies.</p> <p>Note 2: These guidelines may not apply in all situations. Electromagnetic propagation is affected by absorption and reflection from structures, objects, and people.</p>			

1.15 Final disposal

‘Final disposal’ is disposal of the equipment or any part of it, in such a way that it can no longer be used for its intended purpose(s).

Never dispose of Elekta® products into the domestic waste stream.

Disposal must always be executed in an environmentally sensitive manner that complies with all local and international regulations and laws. Materials hazardous to health and the environment must be separately removed and disposed of through competent, licensed facilities. The remaining material should be recycled where facilities and local regulations permit. Prior to disposal, always contact Elekta for advice.

Where applicable, information will be available for treatment facilities and recyclers in accordance with Article 15 of directive 2012/19/EU of the European Parliament and of the Council of 4 July 2012 on waste electrical and electronic equipment (WEEE).

2 Dimensions and weights

2.1 Dewar

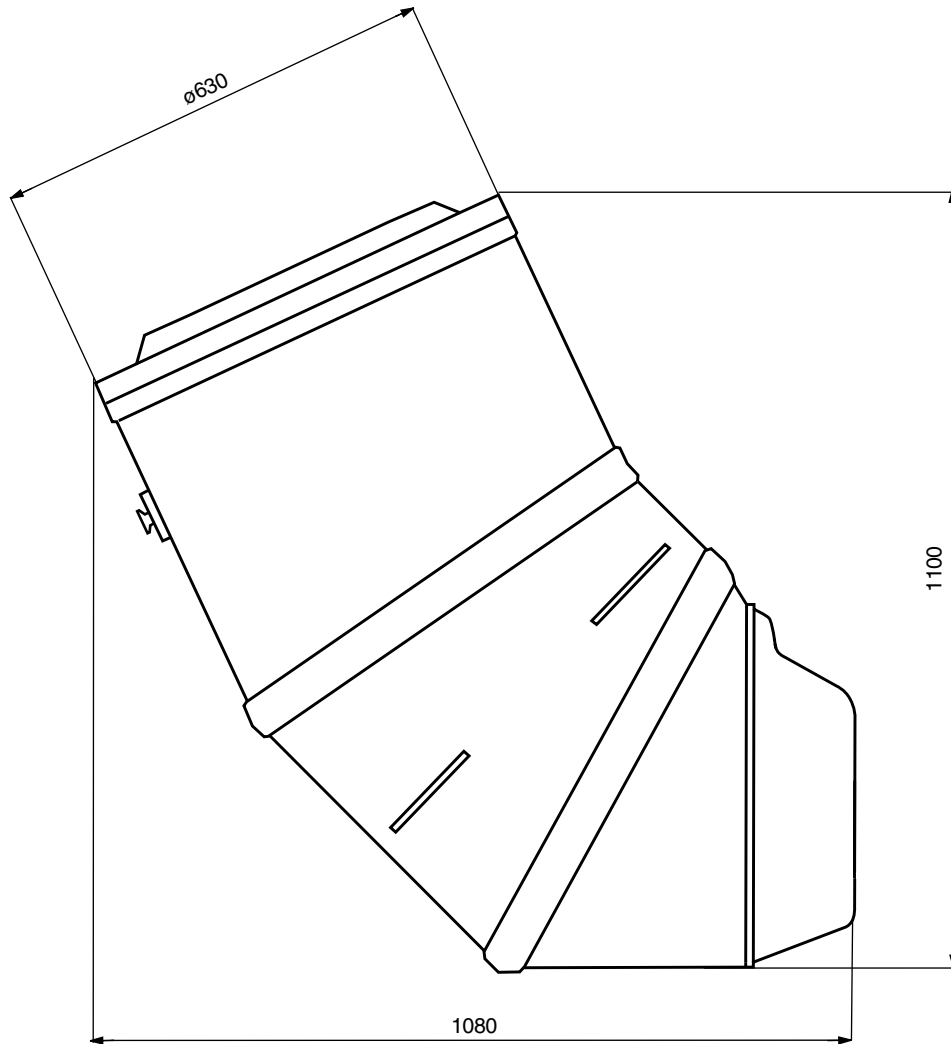

Figure 2.1 Dewar side view. Dimensions in millimeters.

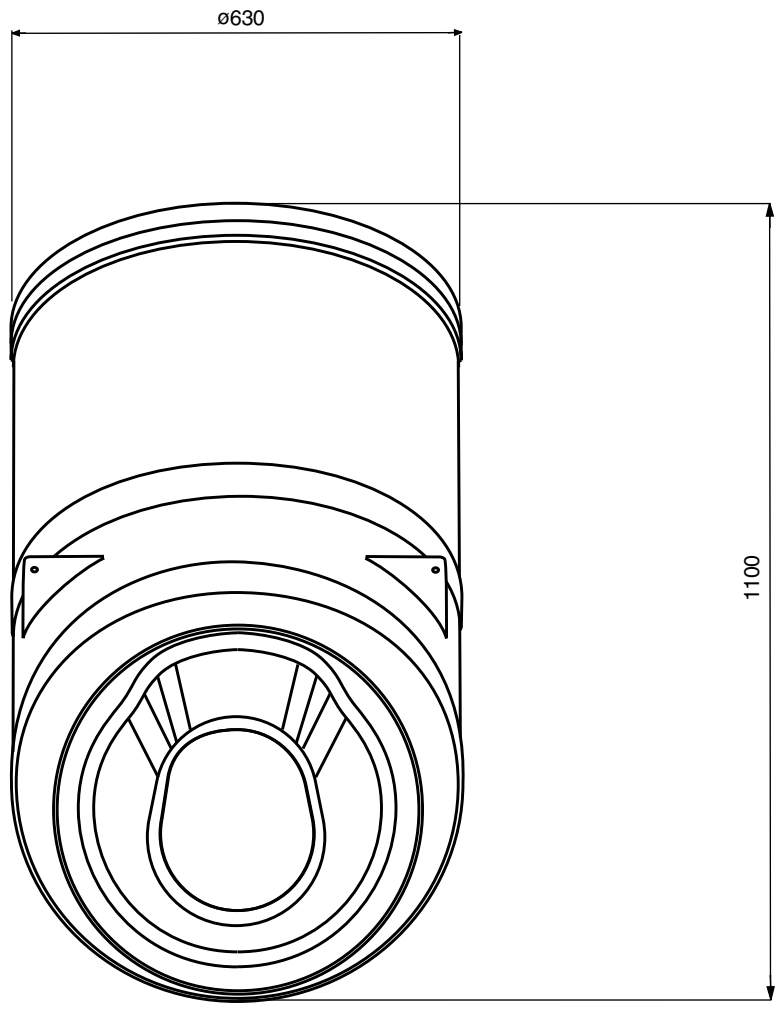

Figure 2.2 Dewar front view. Dimensions in millimeters.

2.2 Probe unit

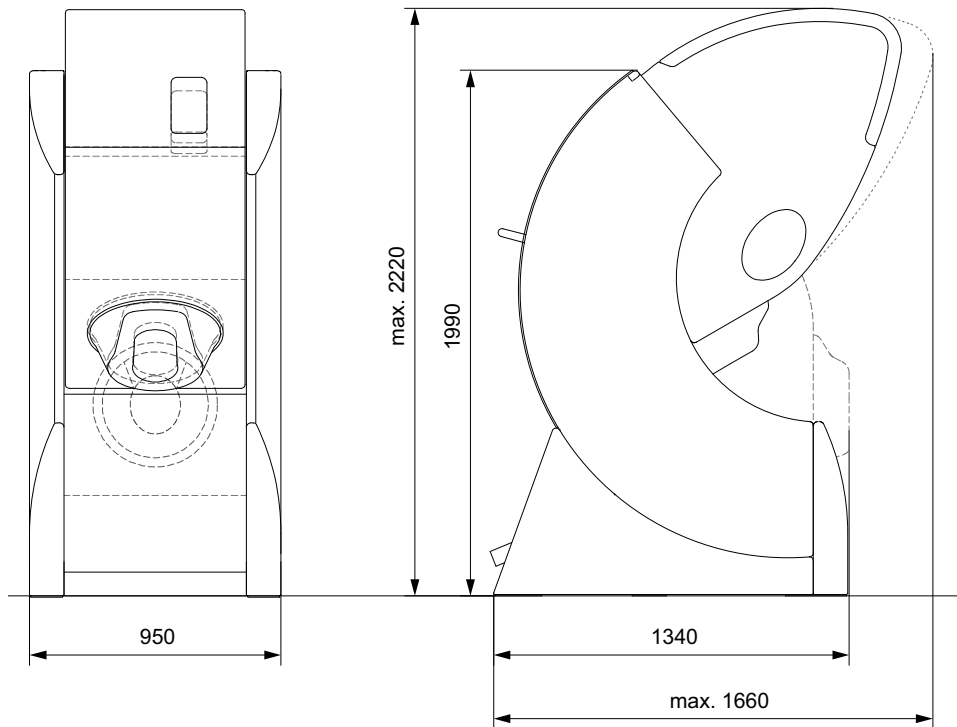

Figure 2.3 Probe unit dimensions in millimeters.

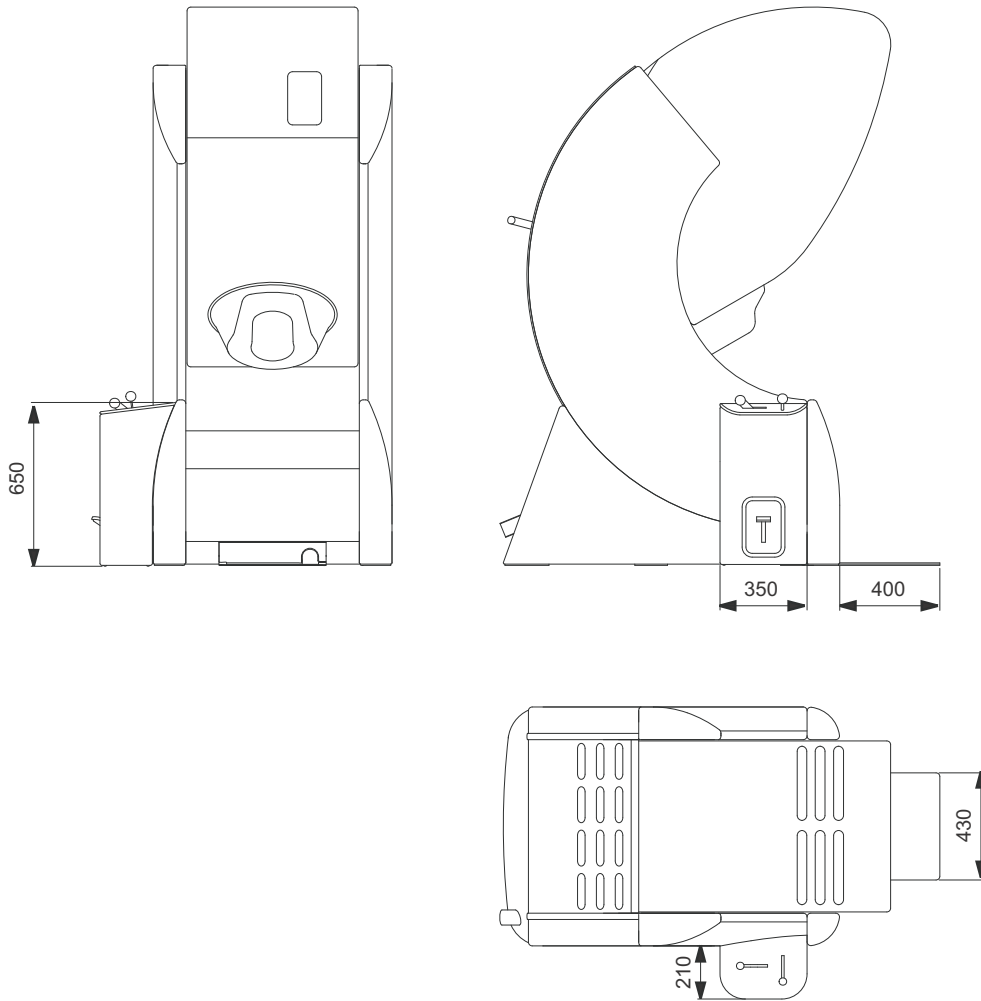

Figure 2.4 The probe unit with chair fine-adjustment system (patient chair option) dimensions in millimeters.

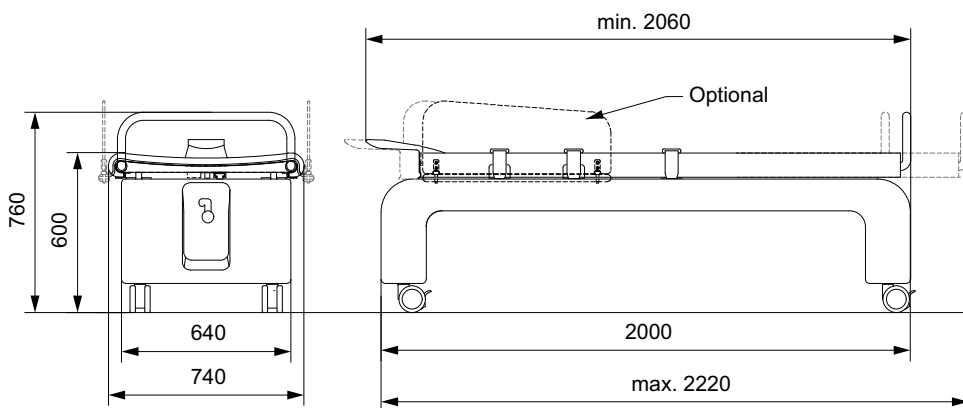

Figure 2.5 The patient couch dimensions in millimeters.

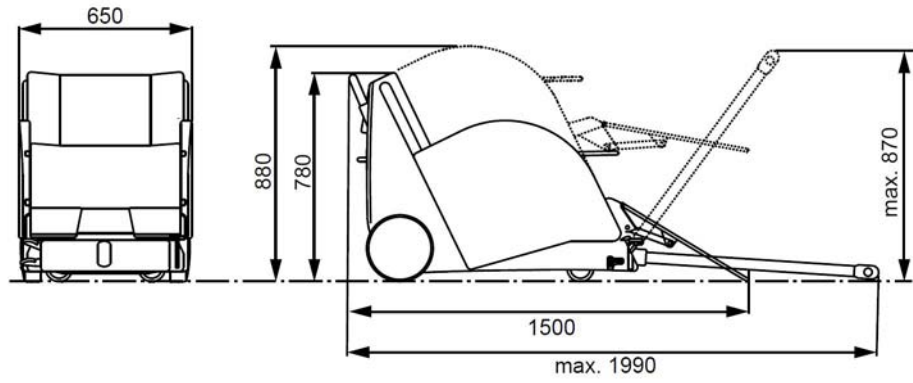

Figure 2.6 The patient chair dimensions in millimeters.

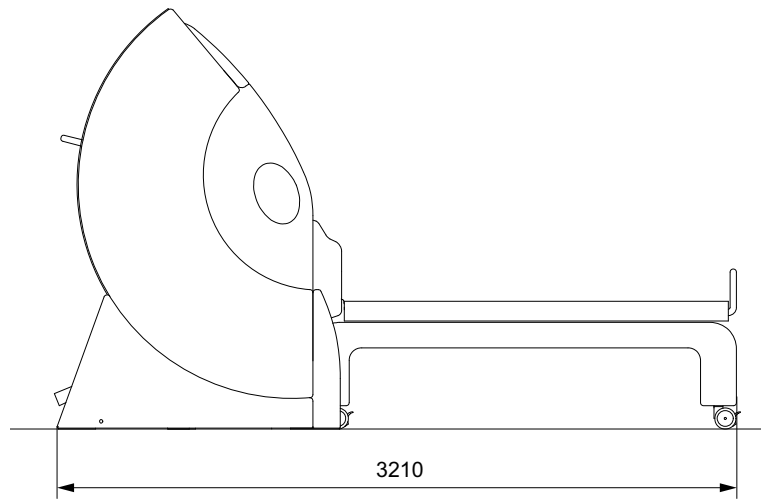

Figure 2.7 The probe unit in supine position with couch. Dimensions in millimeters.

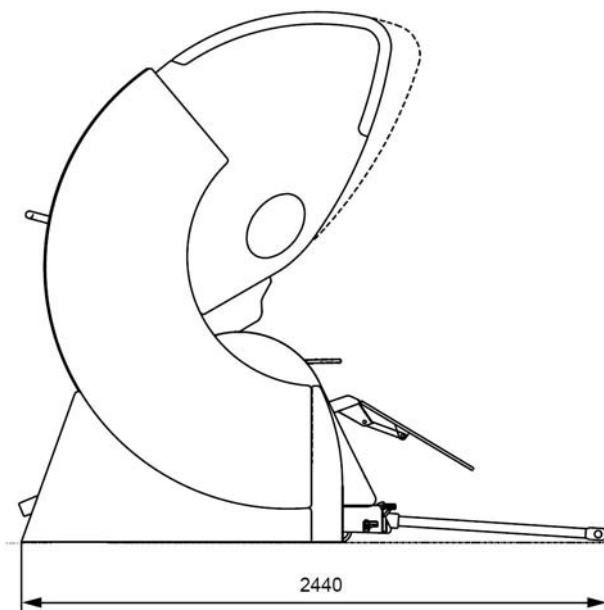

Figure 2.8 The probe unit in seated position with chair. Dimensions in millimeters.

2.3 Electronics cabinets

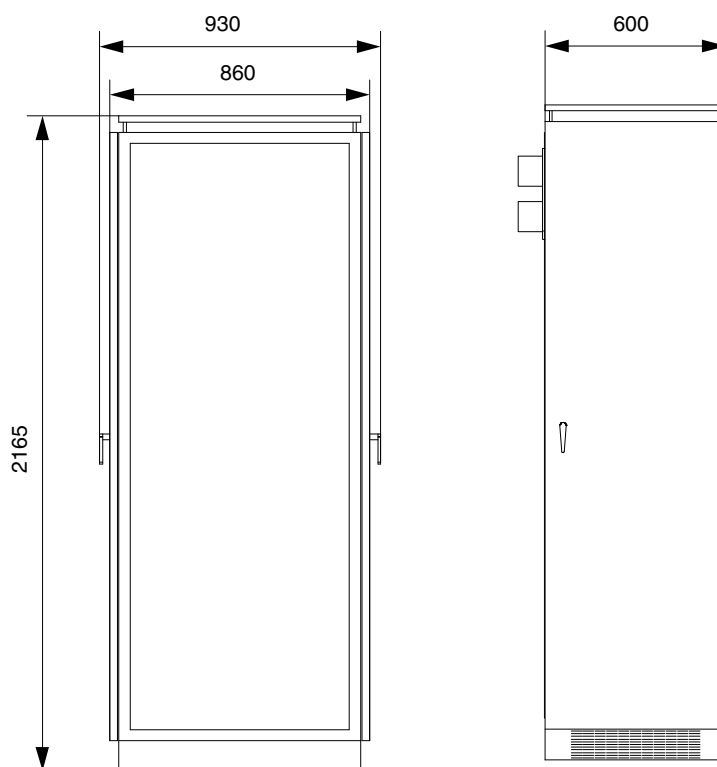

Figure 2.9 Main electronics cabinet dimensions in millimeters.

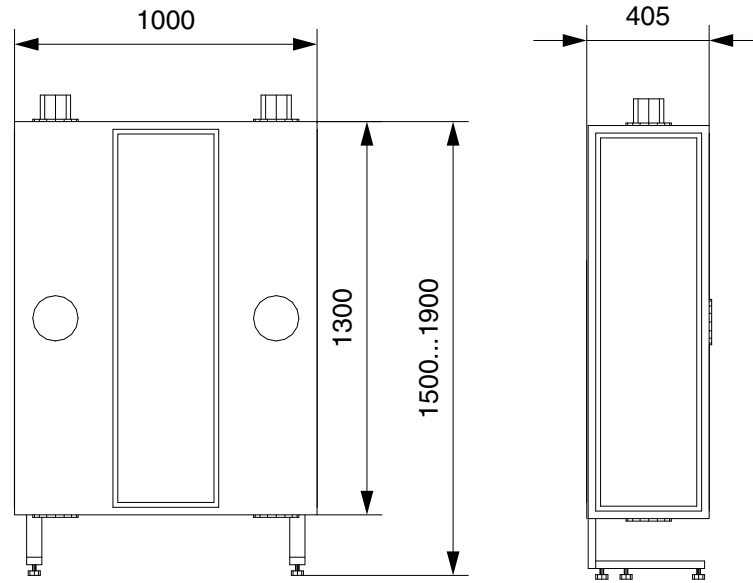

Figure 2.10 Filter cabinet dimensions in millimeters.

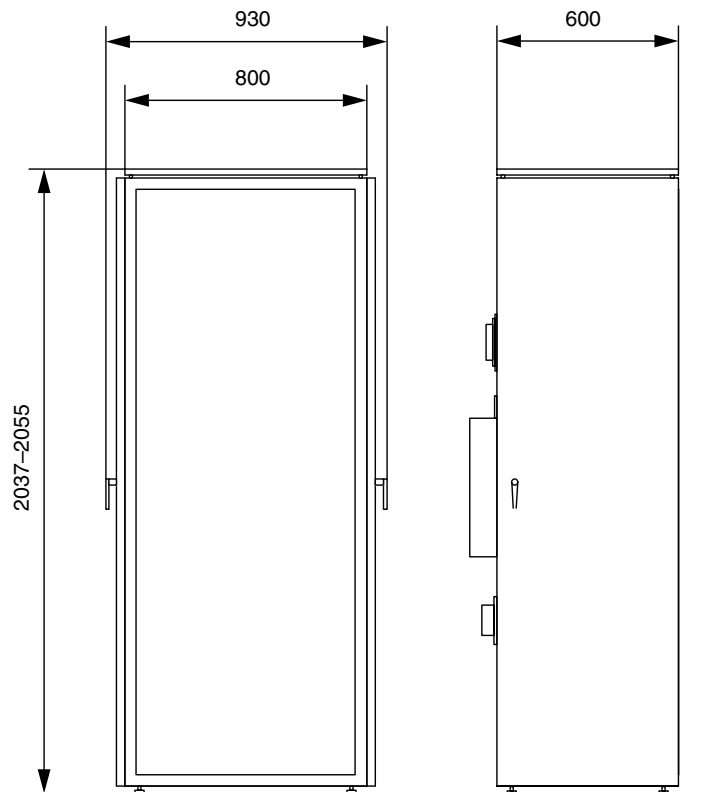

Figure 2.11 Stimulus cabinet dimensions in millimeters.

2.4 Miscellaneous

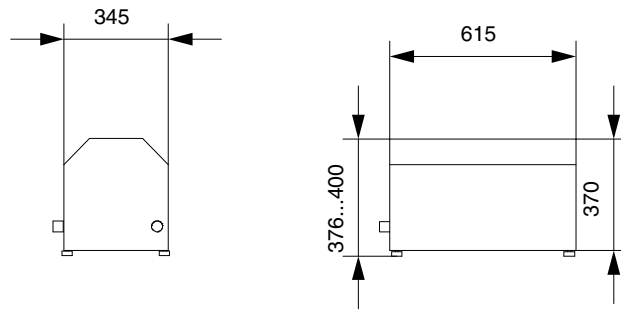

Figure 2.12 The lifting unit dimensions in millimeters.

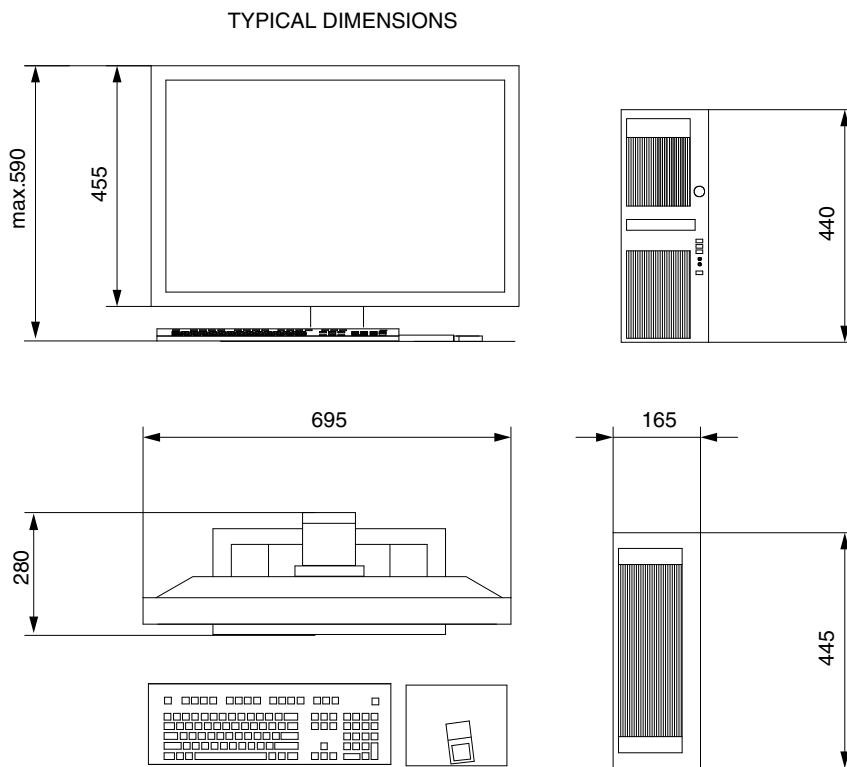

Figure 2.13 Typical workstation dimensions in millimeters.

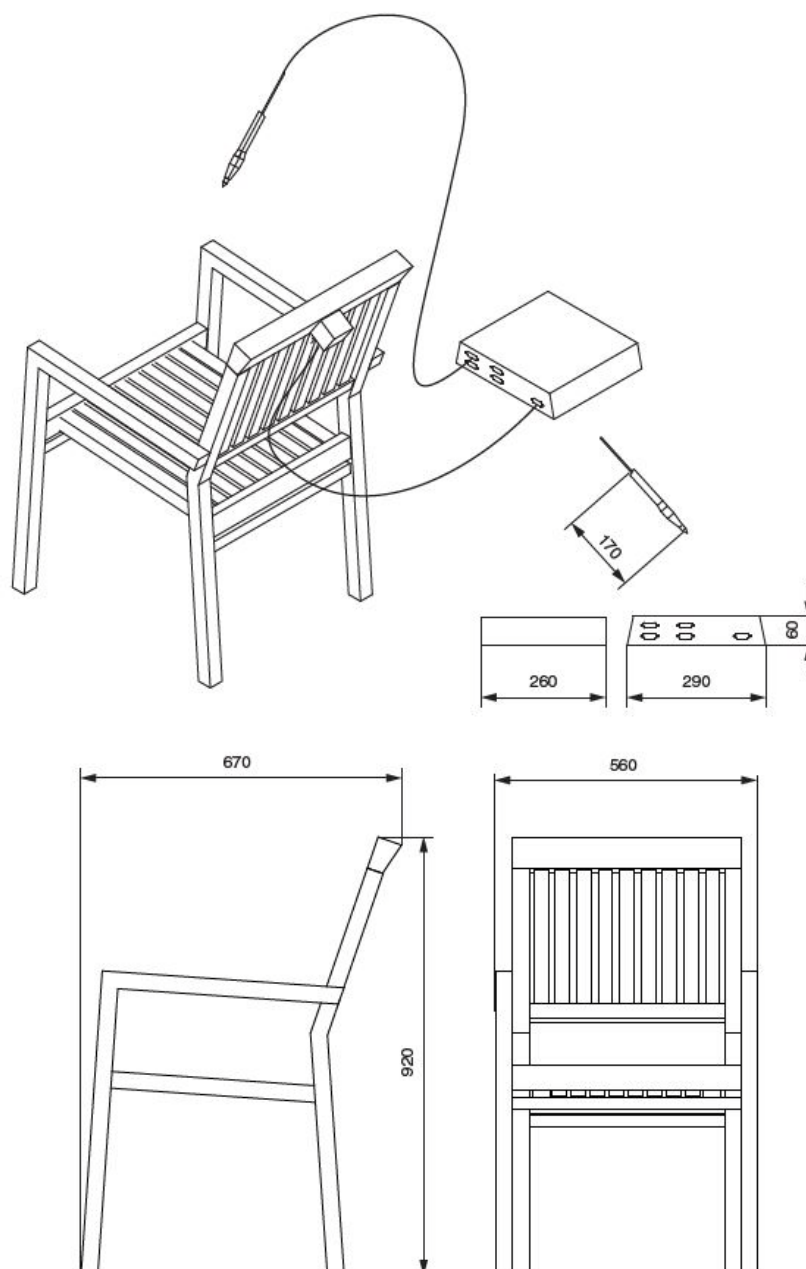

Figure 2.14 The 3D-digitizer and digitizer chair dimensions in millimeters.

2.5 Table of dimensions and weights

Unit	W [mm]	L/D [mm]	H [mm]	Mass [kg]
Measurement unit supine/upright seated	950	1340/1660	1990/2220	400
Measurement unit supine/upright seated with chair fine-adjustment system	1160	1740/1740	1990/2220	425
Measurement unit supine/upright seated, with internal helium recycler	950	1340/1660	2020/2220	450

Unit	W [mm]	L/D [mm]	H [mm]	Mass [kg]
Measurement unit supine/upright seated, with internal helium recycler and chair fine-adjustment system	1160	1740/1740	2020/2220	475
Patient couch, max. (couch surface/maximum)	740	2222	600/760	75
Patient chair, max. (with pull-bar)	650	1990	880	80
Filter unit cabinet (adjustable)	1000	405	1500-1900	150
Electronics cabinet (with handles)	600	930	2165	250
Stimulus cabinet (with handles, adjustable feet)	600	930	2037-2055	100
Acquisition workstation, typ.	165	440	445	25
Analysis workstation, typ.	165	440	445	25
Workstation TFT Monitor, typ (incl stand).	695	240	510	9
HPI chair	565	655	920	10
Phantom	180	180	600	1
Gantry movement unit	370	640	370	30
Control unit of 3-D digitizer	290	265	70	2
Back-projection screen (screen/pedestal)	1180	60/330	1860	35

3 Diagrams

3.1 Probe unit

3.1.1 Sensor array

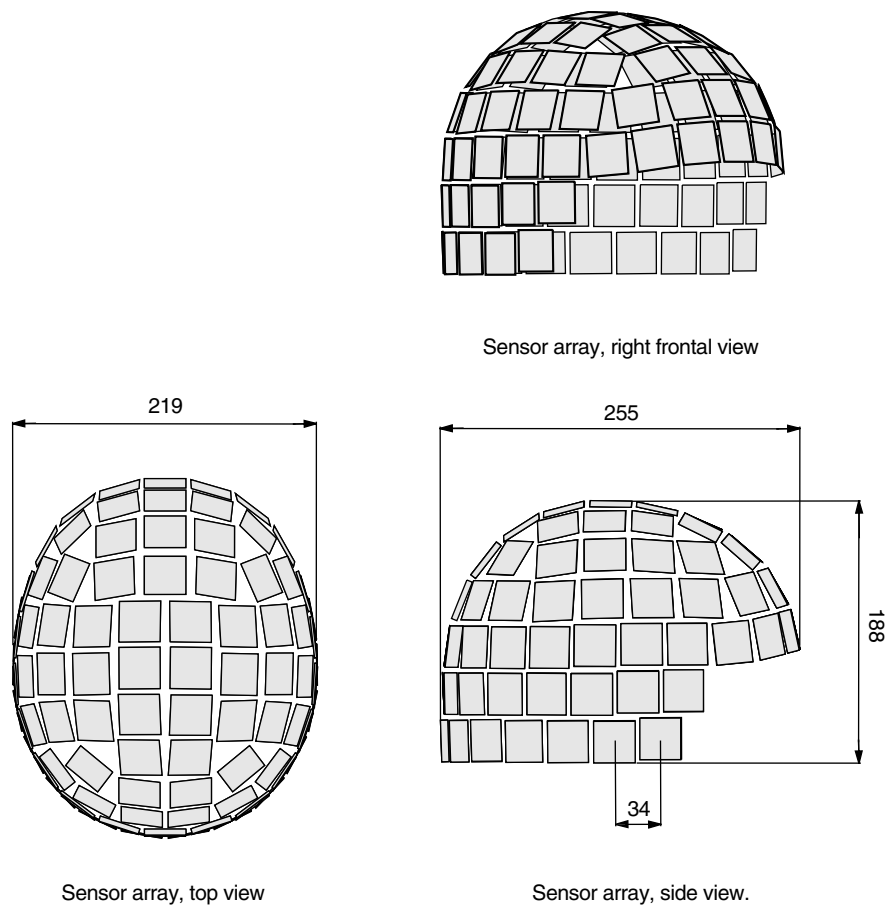

Figure 3.1 Sensor array. Dimensions in millimeters.

3.2 Electronics diagrams

3.2.1 System diagrams

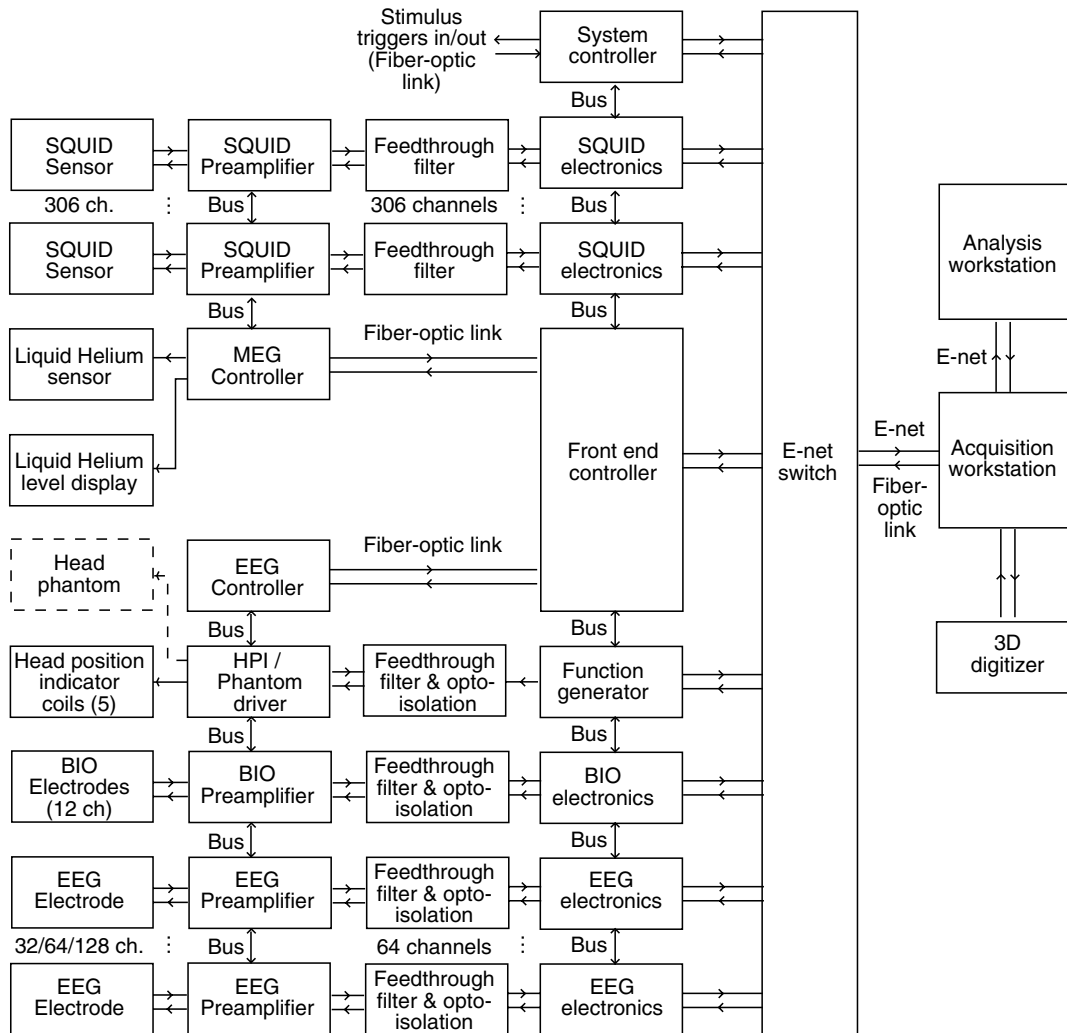

Figure 3.2 Block diagram of the electronics.

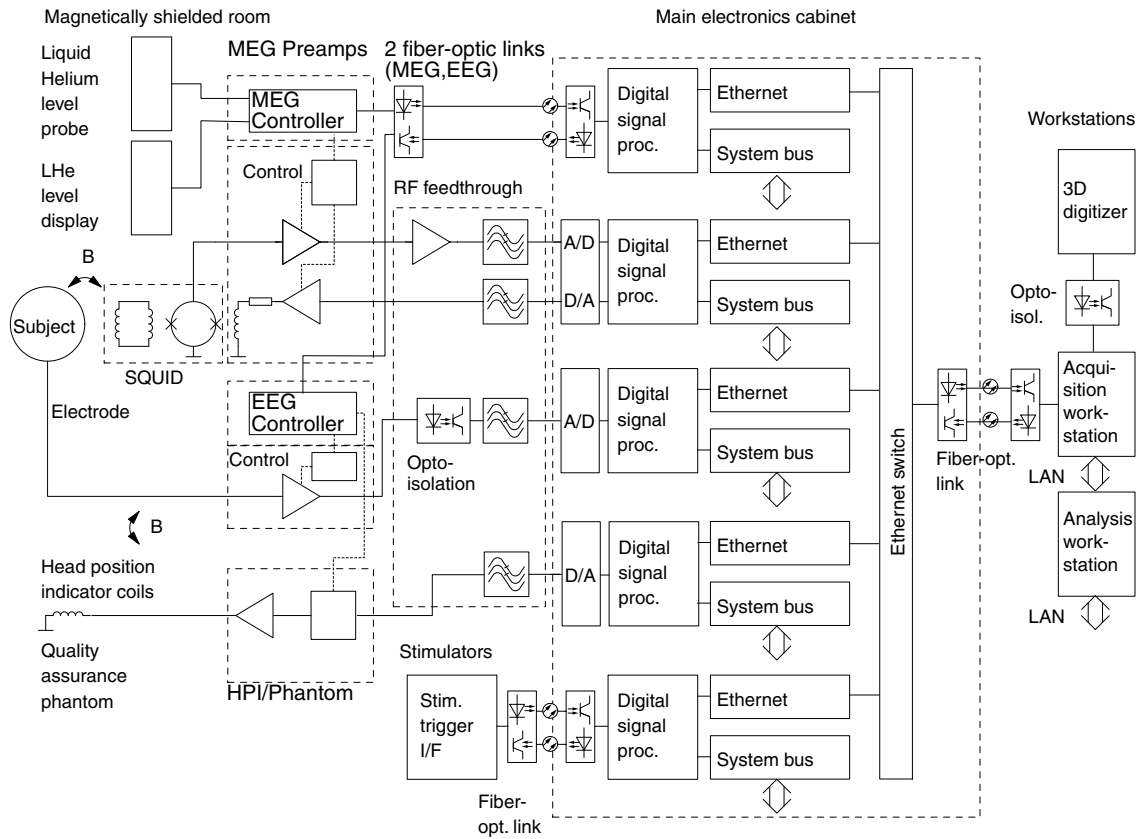

Figure 3.3 Schematic diagram of the electronics.

3.2.2 Bioamplifier/EEG electronics

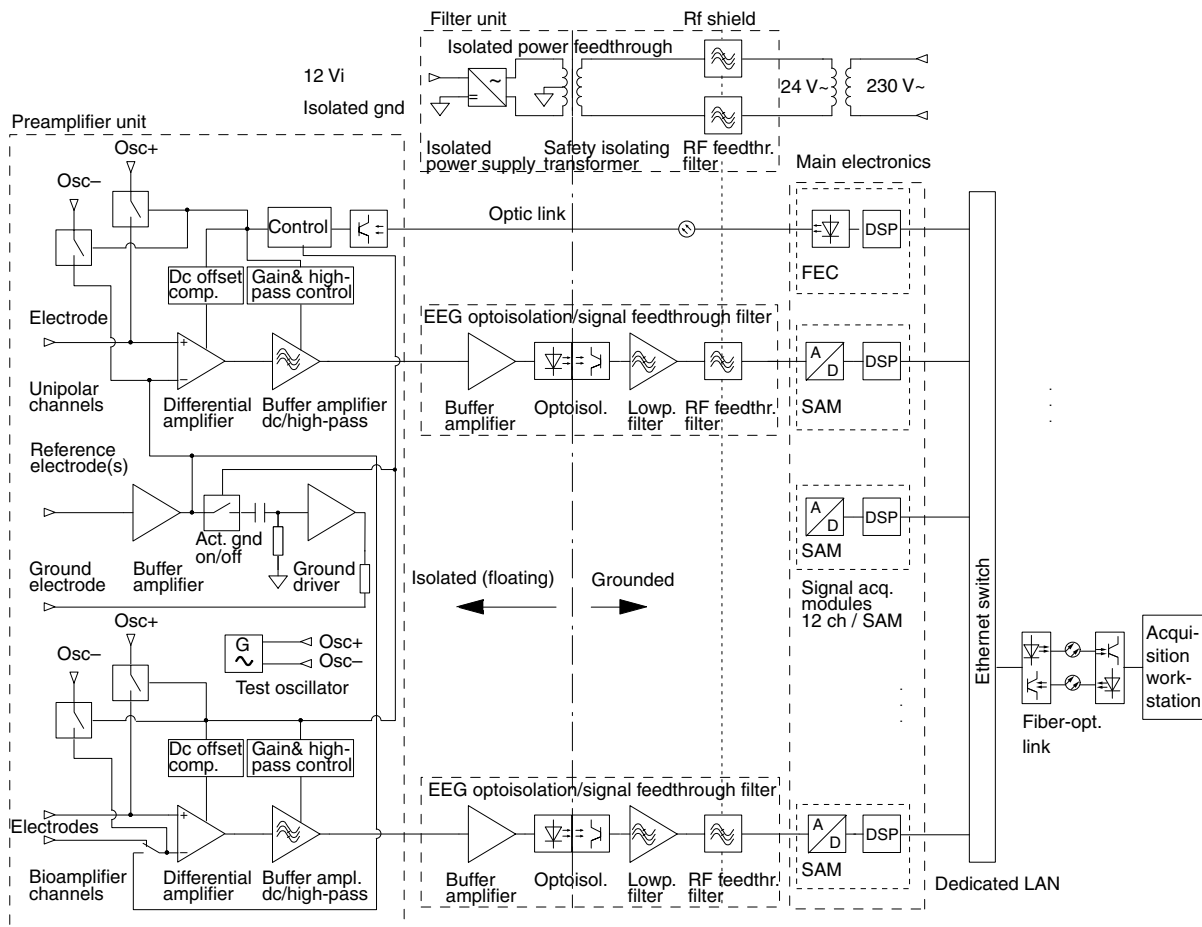

Figure 3.4 Schematic diagram of the EEG electronics

3.2.3 Lifting mechanism

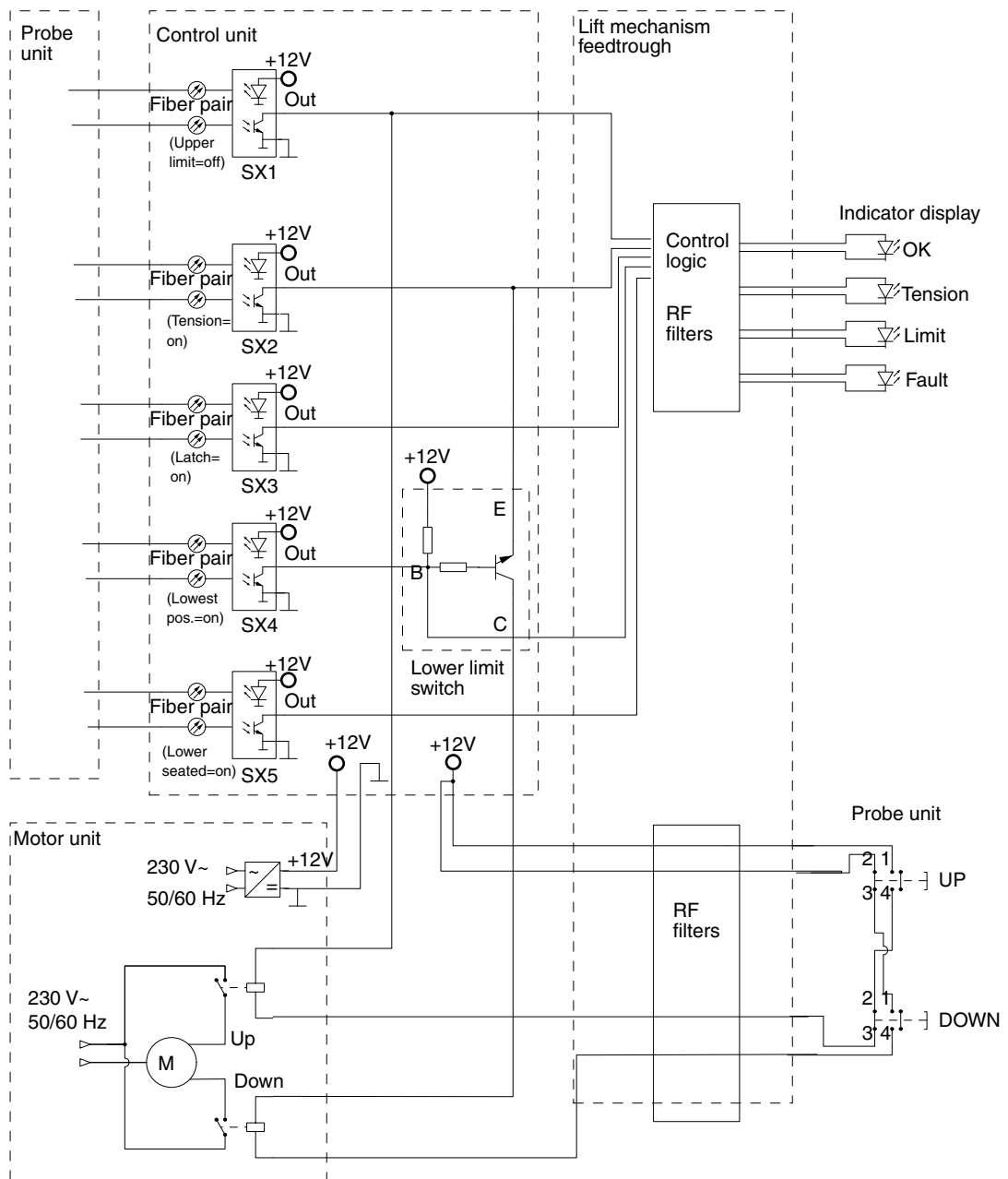

Figure 3.5 Schematic diagram of lifting mechanism

3.2.4 Audio interface

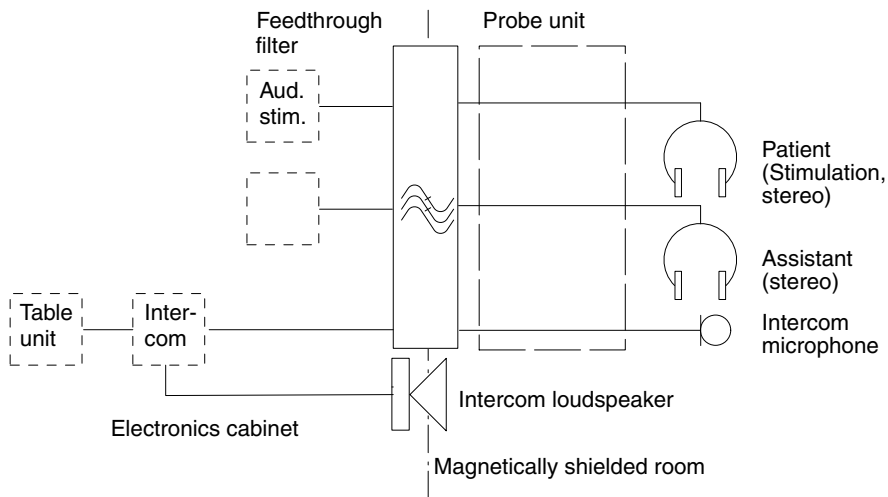

Figure 3.6 Schematic diagram of audio interface

3.3 Powering and grounding

3.3.1 Mains connections

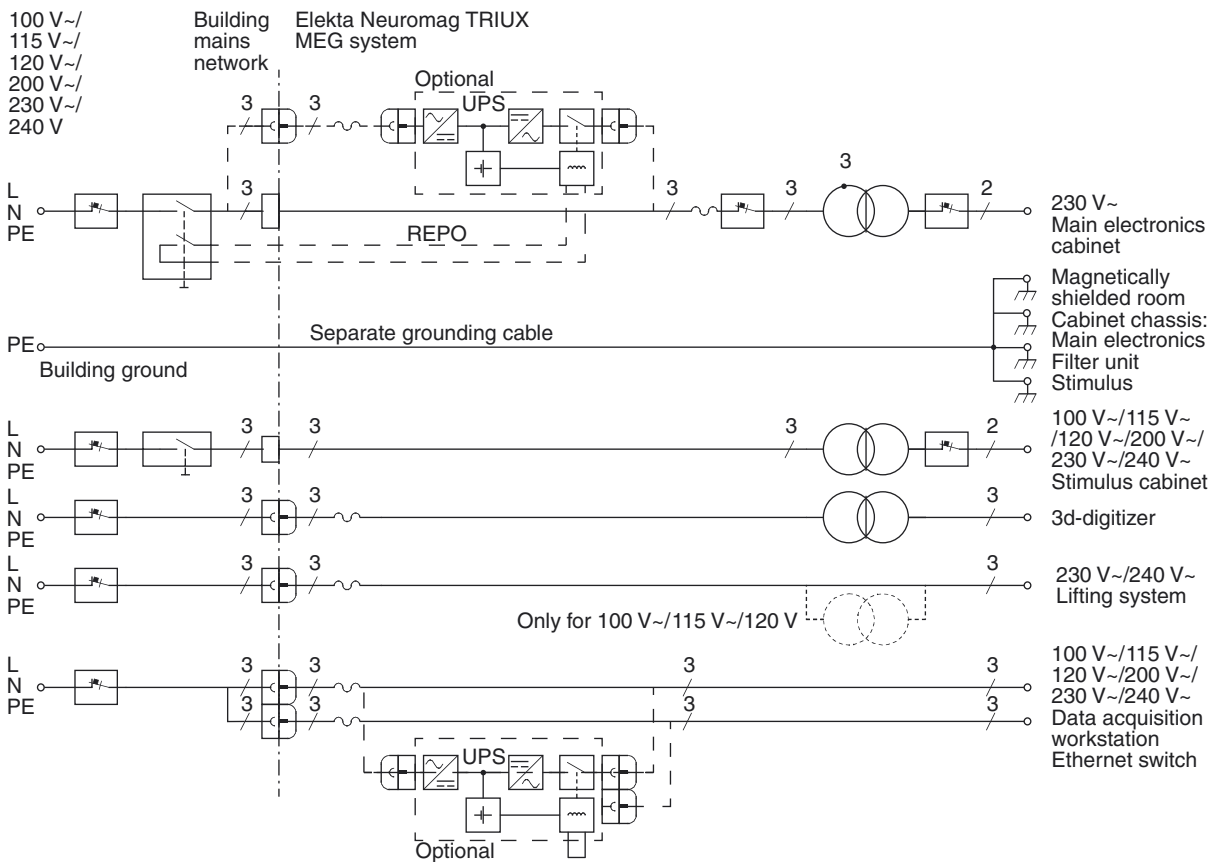

Figure 3.7 Schematic diagram of mains connections. The Uninterruptible Power Supply (UPS) with Remote emergency Power Off (REPO) is optional.

3.3.2 Main electronics cabinet power distribution

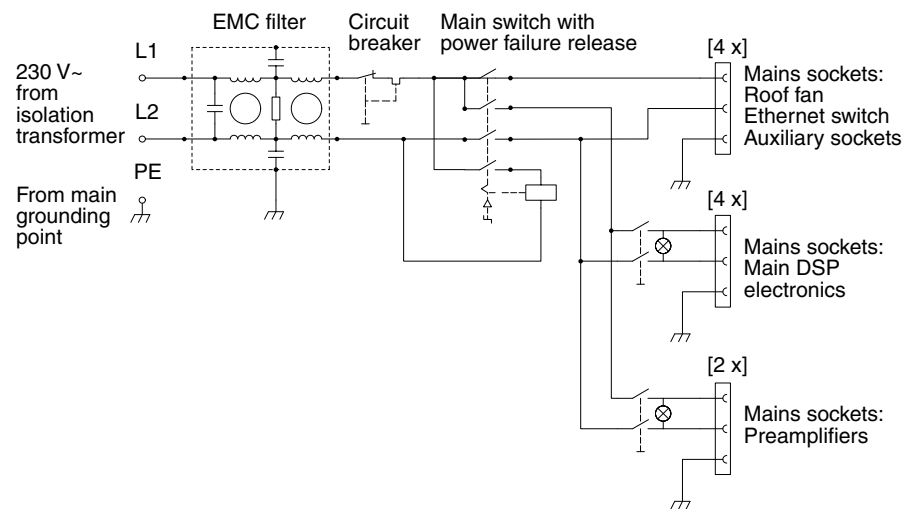

Figure 3.8 Power distribution inside the main electronics cabinet.

3.4 Stimulus cabinet

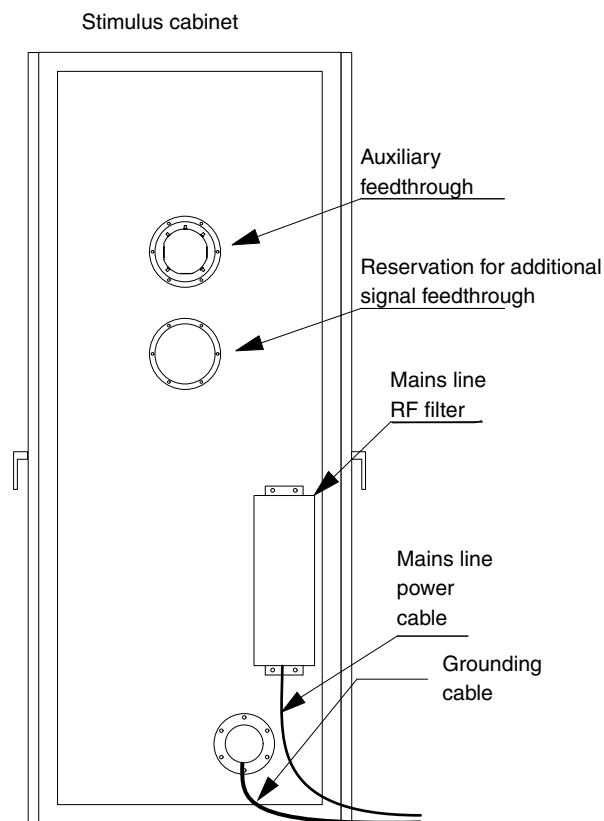

Figure 3.9 Stimulus cabinet, side view (side facing the magnetically shielded room)

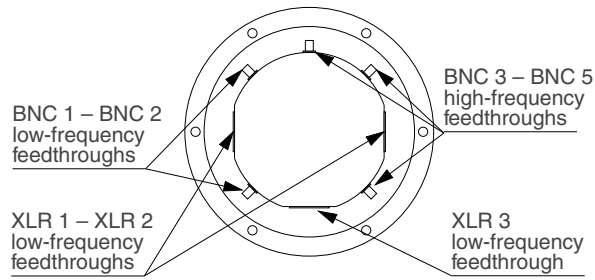

Figure 3.10 Stimulus cabinet's auxiliary signal feedthrough connectors. For specifications of the feedthrough filters, see 1.6.5.

3.5 Networking and data acquisition software

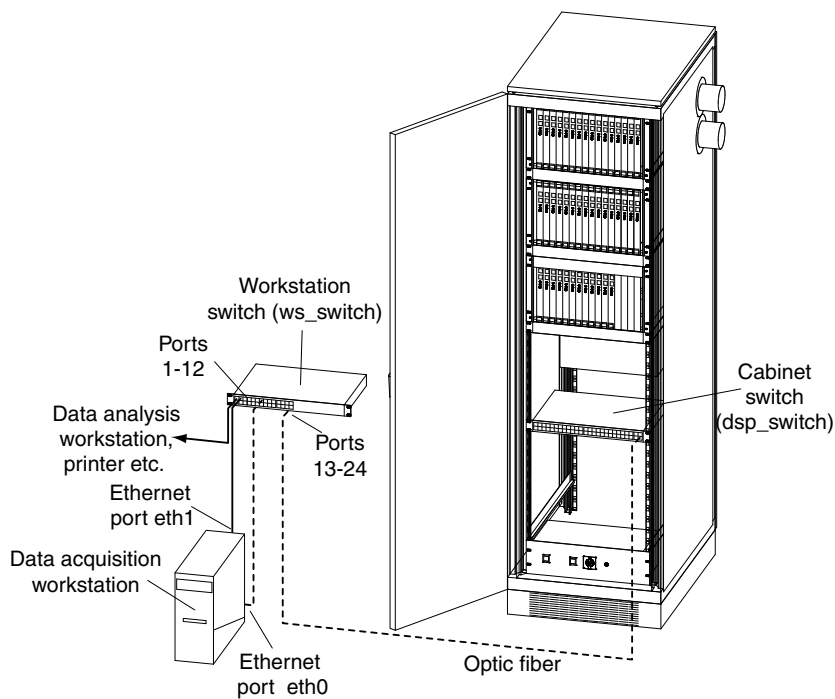

Figure 3.11 Network connections. Ports 13 – 24 of the workstation switch are reserved for the dedicated data acquisition internal network.

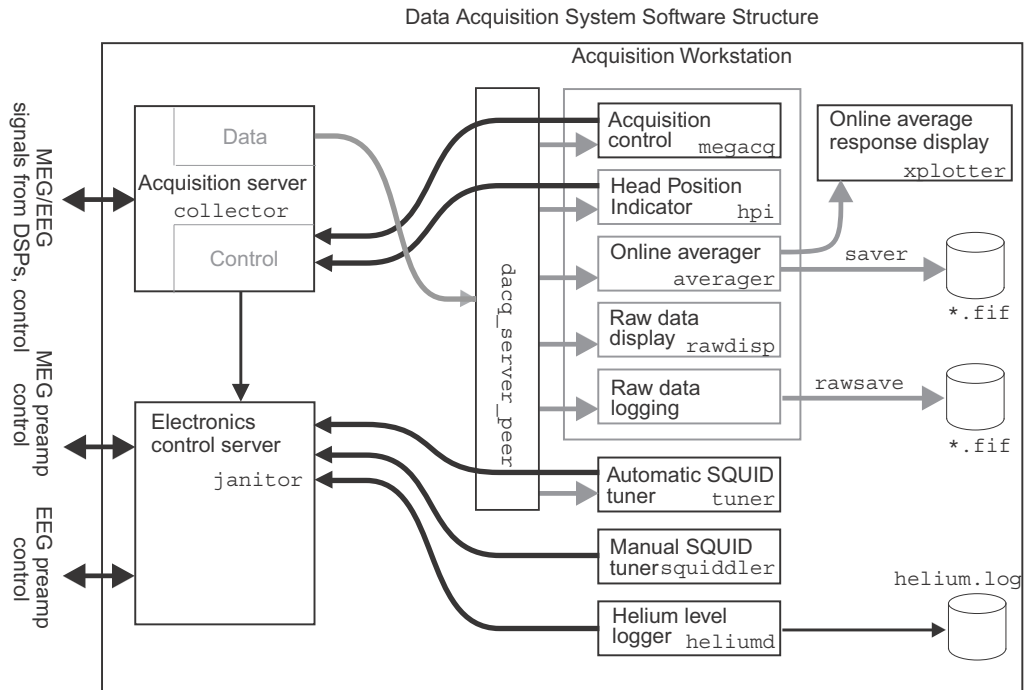

Figure 3.12 Data acquisition software block diagram

www.elekta.com

Human Care Makes the Future Possible

Corporate Head Office:

Elekta AB (publ)
Box 7593, SE-103 93 Stockholm,
Sweden

Tel +46 8 587 254 00
Fax +46 8 587 255 00
info@elekta.com

Regional Sales, Marketing and Service:

North America

Tel +1 770 300 9725
Fax +1 770 448 6338
info.america@elekta.com

Europe, Middle East, Africa,
Eastern Europe, Latin America

Tel +46 8 587 254 00
Fax +46 8 587 255 00
info.europe@elekta.com

Asia Pacific

Tel +852 2891 2208
Fax +852 2575 7133
info.asia@elekta.com

