

JUN-AIR®

Compressor

**Model 3 motor / 3-4 / 6 motor / 6-4 / 6-15 / 6-25
12-25 / 12-40 / 18-40 / 24-40 / 36-150**



Operating manual

Betriebsanweisung

Mode d'emploi

Modo de empleo

Gebruiksaanwijzing

Betjeningsforskrift

JUN-AIR®

GB	Operating manual.....	5
DE	Betriebsanweisung.....	8
FR	Mode d'emploi.....	11
ES	Modo de empleo	14
NL	Gebruiksaanwijzing.....	17
DK	Betjeningsforskrift	20
	Technical specifications.....	23
	Technische Daten	
	Caracteristiques techniques	
	Detalles técnicos	
	Technische gegevens	
	Tekniske specifikationer	
	Diagrams.....	29
	Zeichnungen	
	Dessins	
	Diagramas	
	Tekeningen	
	Diagrammer	
	Spare parts	37
	Ersatzteile	
	Pieces detachées	
	Piezas de recambio	
	Onderdelenlijst	
	Reservevedele	
	Figures	51
	Abbildungen/Illustrationen	
	Photos/illustrations	
	Fotos/ilustraciones	
	Afbeeldingen/illustratie	
	Figures	

Operating manual

Information

Please note that you can find the pictures and illustrations we are referring to on page 51.

Warning

- Unless directions are followed and original spare parts used, physical injury or property damage may result.
- Protect compressor against rain, moisture, frost, and dust.
- Compressor is only suitable for installations with the nominal voltage stated on the motor plate.
- Do not in any way block or prevent the normal functioning of the safety valve on the receiver.
- Only connect pneumatic equipment suitable for the max. pressure indicated.
- Do not operate compressor at ambient temperatures exceeding 35°C/95°F or falling below 0°C/32°F.
- Do not touch compressor motor during operation as there is a risk of burn due to high temperatures.
- Do not direct air flow at head or body.
- When a flammable liquid is sprayed, there may be danger of fire or explosion, especially in closed rooms.
- Always keep the compressor out of reach of children.

Guarantee

Provided that the operational instructions have been carried out, your JUN-AIR compressor is guaranteed against faulty material or workmanship for 2 years.

The air receiver is guaranteed for 5 years.

The guarantee does not cover damage caused by violence, misuse, incorrect repairs or use of wrong oil and unoriginal spare parts.

Costs of transportation of parts/equipment are not covered by the guarantee.

JUN-AIR's Conditions for Sale and Delivery will generally apply. JUN-AIR International A/S reserves the right to change technical specifications/ constructions.

How to operate the JUN-AIR compressor

Your JUN-AIR compressor is very easy to operate. Observe the following simple instructions and you will get many years' service from your compressor.

1. Visually inspect unit for shipping damage, contact your supplier immediately if you think the unit may have been damaged.
2. Always keep the compressor in a vertical position during use and transportation.
3. Place the compressor in a dustfree, dry and cool, yet frostfree, room. Do not install in a closed cupboard, unless adequate openings for ventilation are available (fig. 1). Ensure that the compressor stands firmly on the floor.

4. Replace the cap on the air intake tube with the intake filter (fig. 2).
5. Connect pneumatic equipment.

Important!

The compressor oil may be aggressive towards certain gasket materials used in pneumatic equipment. We recommend Teflon, Viton, etc.. Do not use polycarbonate filter bowls. Contact your local JUN-AIR distributor if you need further information.

6. Plug the compressor into an outlet switch of nominal voltage and ensure that fusing is adequate (see Technical Details).
7. Start the compressor using the 0/1 switch on the pressure switch (fig. 3). The compressor will automatically switch off at the preset pressure. If the motor does not start it may be due to pressure in the receiver, and the motor will then start automatically when the pressure reduces to approx. 6 bar/87 psi.
8. Always keep the compressor in a vertical position as oil may run out of the intake filter. During transportation, mount the cap on the inlet. Mechanical noise from the compressor in connection with handling does not have any functional importance.

Warning!

Never mount the transportation cap on oil-lubricated compressors while there is still pressure in the compressor & pressure vessel, as this may cause a pressure build up in the motor housing.

9. Adjustment of pressure (fig. 4):

A: Max. pressure adjustment (cut-out)

B: Differential adjustment (cut-in)

The cut-in pressure (normally 6 bar) is set by adjustment of differential screw B. Turn clockwise to reduce cut-in pressure.

The cut-out pressure is set by even adjustment of the two screws A. (Cut-in pressure + differential = cut-out pressure). Turn clockwise to increase cut-out pressure.

The switch is normally factory set for operation at 6-8 bar (approx. 90-120 psi).

10. Adjustment of CONDOR 4-16 press-switch (fig. 4a)

The cut-out pressure (normally 16 bar) is set by adjustment of maximum pressure screw. (Cut-in pressure + different pressure = cut-out pressure). Turn clockwise to increase cut-out pressure.

The cut-in pressure (normally 14 bar) is set by adjustment of differential screw. Turn clockwise to reduce cut-in pressure.

The switch is normally from the factory set for operation at 14-16 bar.

Technical details

The max. operation of the compressor is 50% of the operation time, and the max. operation time is 15 min. at 8 bar/120 psi in each cycle. Consequently, 15 min. standstill is required before the next start. For tables with technical data and performance curves, see page 23.

Preventive compressor maintenance

	Weekly	Monthly	Annually
Check oil level. During standstill the correct level is between the maximum and the minimum indications. Use only genuine SJ-27 synthetic oil. Do not overfill (fig. 5).	•		
Drain condensate from air receiver (at a pressure of max. 2 bar/30 psi) (fig. 6). If fitted with auto drain, this will take place automatically, however, drain bottle has to be emptied.	•		
If compressor is fitted with outlet filter, check and empty for water by pressing the black button. If fitted with auto drain, this will take place automatically.	•		
Check compressor, air tubes and equipment for leaks, and check the pumping time.		•	
Inspect and replace intake filter, if necessary.		•	
Clean the compressor with a soft, damp cloth. Dust and dirt prevent cooling.		•	
Check the O-ring in the non-return valve and replace if necessary (fig. 10) Note! Empty receiver of air before dismantling.			•
Check filter and filter elements for optimum efficiency.			•
Test the safety valve by gently pulling the ring with pressure in the receiver (fig. 7).			•

Oil change

In connection with repair of model 6 motors, e.g. change of valve plate or other internal motor parts or in case the compressor is installed in a very dusty environment, oil change may be necessary. Proceed as follows:

1. Remove the ribbed cover by loosening the 4 screws (fig. 8).
2. Tilt the motor towards side with outlet and at the same time hold the internal motor parts in place with hand. Pour all oil out of housing (fig. 8). In case of dirt particles at the bottom of the motor housing, clean with a rag.

Note!

Waste oil is to be handled according to the environmental rules in force in the country.

3. Tilt the motor back and fill with SJ-27 oil (approx. 0.75l) (fig. 8).
4. Clean the edge of casing and cover. Check the O-ring of the ribbed cover.
5. Replace the ribbed cover and check during operation that the O-ring is placed correctly to ensure a 100% tight closing between housing and cover.

Important!

Always use SJ-27 oil as other types of oil may cause serious mechanical damage to the compressor. Consequently, the warranty only applies if SJ-27 oil is used.

Check the pumping time

The pumping time indicates the condition of the compressor provided that there are no leaks in the system where the compressed air may leak. Test the compressor as follows:

1. Empty the air receiver of compressed air (the pressure gauge shows 0 bar).
2. Close the outlet on the air receiver and check that the drain cock is closed.
3. Start the compressor and note how long it takes until it switches off.
Make sure that the pressure in the air receiver is 8 bar/120 psi as deviations may indicate the wrong results (see technical details).

Important!

Always test the compressor when cold as the time indicated refers to the pumping time of a cold compressor. The pumping time of a warm compressor is much longer and consequently, the result would be misleading.

Fault finding and repair

Important!

Switch off and isolate from electrical supply before removing any parts from the compressor. Empty air receiver of air before dismantling any parts of compressor unit's pressure system.

1. Compressor does not start:

- a) No power from mains. Check fuses and plug.
- b) Breakage or loose joints in electrical connections.
- c) The starting relay is defective. Contact your JUN-AIR distributor.
- d) The pressure switch is defective and does not switch on the compressor.
- e) The thermal protection has switched off the compressor due to overheating. When cooled the compressor will automatically turn on at a suitable operation temperature. Go through the points in section 4.
- f) Pressure in the air receiver is too high for activation of the pressure switch. The pressure switch makes circuit only when pressure has dropped to preset start pressure. Empty the receiver.
- g) The compressor has not been unloaded and there is back pressure on the piston. Dismount and check unloader valve (fig. 9). The back pressure may be due to a leaking non-return valve causing the compressed air in the receiver to leak back into the compressor motor. Dismount the non-return valve and clean or change O-ring (fig. 10).
- h) Capacitor defective.

2. Compressor operates, but pressure does not increase in tank (or increases too slowly):

- a) The cap on the intake tube has not been removed and replaced by the intake filter (fig. 2).
- b) Intake filter is clogged. Replace.
- c) Leaks in fittings, tubes or pneumatic equipment. Check with soapy water. Pressure drop is not to exceed 1 bar per hour.
- d) Clogged non-return valve or pressure pipe. Clean or replace the parts (fig. 10).
- e) Air leaks from the unloader valve when the compressor is operating. Check or replace the unloader valve (fig. 9).
- f) Defective valve plate. Contact your JUN-AIR distributor.

3. Loud noise from compressor:

- a) Most likely broken suspension spring(s). Replace the spring and ensure that motor position is horizontal.
- b) The internal pressure pipe touches the rib cover or the cylinder block. Dismount the rib cover and bend the pressure pipe away.

4. Compressor gets very hot and/or uses a lot of oil:

- a) Incorrect oil level. The level must appear in the oil level glass (fig. 5).
- b) Wrong oil has been filled in the compressor. Use only SJ-27 synthetic lubricant which has the correct viscosity.
- c) Leaks. See point 2c.
- d) Clogged intake filter. See point 2b.
- e) Too high ambient temperature. Do not install the compressor in a cabinet unless adequately ventilated (fig. 1).
- f) The compressor is overloaded (i.e. it is operating more than 50% of the operation time). Contact your JUN-AIR distributor.

5. Compressor starts when no air is being used:

- a) Leaks. See point 2c.

6. Compressor starts and stops more frequently than usual:

- a) Condensate in the air receiver. Empty the receiver by means of the drain cock (fig. 6).
- b) Leaks. See point 2c.

Pressure vessel

Pressure tested at:	4-25 liter:	24 bar
	40-50 liter:	18.3 bar

Directions for use

Application	Receiver for compressed air.
Receiver specifications	See name plate.
Installation	Tubes, etc. must be made of suitable materials.
Placement	Observe the working temperature of the receiver. Ensure that sufficient room for inspection/maintenance is available in a horizontal position. The receiver must be kept in a horizontal position.
Corrosion protection	The surface treatment must be maintained as required. Internal inspection at least every 5 years.

Alternation/repair	Drain moisture at least once a week. No welding must be made on pressurized parts.
Safety valve	Ensures that PS will not be exceeded. Never adjust to a higher pressure than PS. The capacity of the valve must be calculated in accordance with the volume of air supplied by the compressor. (PS = Maximum working pressure of the receiver)

Declaration of Conformity

NOTE: The declaration of conformity is only valid for units operating at 230 V/50 Hz, 3x400 V/50 Hz, 12 V DC or 24 V DC.

The manufacturer, JUN-AIR International A/S, declares that the products mentioned in this manual are in conformity with:

- 87/404/EEC - 90/488/EEC - 93/68/EEC Council Directive relating to Simple Pressure Vessels
- 89/392/EEC - 91/368/EEC - 93/44/EEC - 93/68/EEC Council Directive of Safety of Machinery
- 89/336/EEC Council Directive of Electric Magnetic Compatibility
- 73/23/EEC Low-voltage Directive

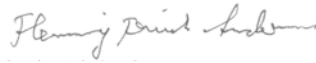

Flemming Frisch Andersen
Test and Certification Administrator

Technical specifications

Motor size		3											
Voltage	Volt	100	100	120	200	200	230	230					
Frequency	Hz	50	60	60	50	60	50	60					
Power	HP	0,20	0,20	0,20	0,18	0,18	0,18	0,18					
	kW	0,15	0,15	0,15	0,13	0,13	0,13	0,13					
Displacement	l/min	17	20	20	17	20	17	20					
	CFM	0,60	0,71	0,71	0,60	0,71	0,60	0,71					
FAD @ 8 Bar ***	l/min	11	13	13	11	13	11	13					
	CFM	0,39	0,46	0,46	0,39	0,46	0,39	0,46					
Max. pressure**	Bar	8	8	8	8	8	8	8					
	PSI	120	120	120	120	120	120	120					
Max. current	Amps	2,8	2,7	2,4	0,9	0,9	0,9	0,9					
Noise level @ 1 m	dB(a)	35	35	35	35	35	35	35					
Weight	Kg	9											
	Lbs	20											
Dimensions (l x w x h)	mm	290 x 190 x 210											
	Inch	11.4 x 7.5 x 8.3											

Motor size		6											
Voltage	Volt	100	100	120	200	200	230	230					
Frequency	Hz	50	60	60	50	60	50	60					
Power	HP	0,54	0,54	0,54	0,46	0,46	0,46	0,46					
	kW	0,40	0,40	0,40	0,34	0,34	0,34	0,34					
Displacement	l/min	50	60	60	50	60	50	60					
	CFM	1,77	2,12	2,12	1,77	2,12	1,77	2,12					
FAD @ 8 Bar ***	l/min	32	37	37	32	37	32	37					
	CFM	1,13	1,31	1,31	1,13	1,31	1,13	1,31					
Max. pressure**	Bar	8	8	8	8	8	8	8					
	PSI	120	120	120	120	120	120	120					
Max. current	Amps	5,7	5,2	6,2	2,9	2,9	2,9	2,9					
Noise level @ 1 m	dB(a)	45	45	45	45	45	45	45					
Weight	Kg	14											
	Lbs	31											
Dimensions (l x w x h)	mm	280 x 190 x 240											
	Inch	11.0 x 7.5 x 9.4											

Motor size		12										
Voltage	Volt	100	100	120	200	200	230	230				
Frequency	Hz	50	60	60	50	60	50	60				
Power	HP	1,08	1,08	1,08	0,92	0,92	0,92	0,92				
	kW	0,79	0,79	0,79	0,68	0,68	0,68	0,68				
Displacement	l/min	100	120	120	100	120	100	120				
	CFM	3,53	4,24	4,24	3,53	4,24	3,53	4,24				
FAD @ 8 Bar ***	l/min	64	74	74	64	74	64	74				
	CFM	2,26	2,61	2,61	2,26	2,61	2,26	2,61				
Max. pressure**	Bar	8	8	8	8	8	8	8				
	PSI	120	120	120	120	120	120	120				
Max. current	Amps	11,4	10,4	12,4	5,8	5,8	5,8	5,8				
Noise level @ 1 m	dB(a)	48	48	48	48	48	48	48				

* Neutral is required

Technical modifications reserved

** Higher pressure available upon request

Compressor unit

Model			3-4	6-4	6-15	6-25
Tank size	liter		4	4	15	25
	US gallon		1,1	1,1	4,0	6,6
Weight	kg		18	23	26	29
	lbs		40	51	57	64
Dimensions (l x w x h)		mm	384 x 333 x 342	384 x 333 x 342	378 x 378 x 485	378 x 378 x 555
		Inch	15.1 x 13.1 x 13.5	15.1 x 13.1 x 13.5	14.9 x 14.9 x 19.1	14.9 x 14.9 x 21.9
Pumping time (0-8 bar/0-120 psi)	@ 50 Hz	sec.	160	60	220	365
	@ 60 Hz	sec.	135	50	185	305
Noise level @ 1 m	@ 50 Hz	dB(a)	35	45	45	45
	@ 60 Hz	dB(a)	35	45	45	45

Model			12-25	12-40	18-40	24-40
Tank size	liter		25	40	40	40
	US gallon		6,6	10,6	10,6	10,6
Weight	kg		45	48	62	84
	lbs		99	106	137	185
Dimensions (l x w x h)		mm	425 x 400 x 595	556 x 446 x 581	556 x 446 x 557	556 x 446 x 623
		Inch	16.7 x 15.7 x 23.4	21.9 x 17.6 x 22.9	21.9 x 17.6 x 21.9	21.9 x 17.6 x 24.5
Pumping time (0-8 bar/0-120 psi)	@ 50 Hz	sec.	185	275	185	140
	@ 60 Hz	sec.	155	225	150	115
Noise level @ 1 m	@ 50 Hz	dB(a)	48	48	50	56
	@ 60 Hz	dB(a)	48	48	50	56

Model			36-150			
Tank size	liter		150			
	US gallon		39,6			
Weight	kg		164			
	lbs		362			
Dimensions (l x w x h)		mm	1287 x 454 x 775			
		Inch	50.7 x 17.9 x 30.5			
Pumping time (0-8 bar/0-120 psi)	@ 50 Hz	sec.	345			
	@ 60 Hz	sec.	285			
Noise level @ 1 m	@ 50 Hz	dB(a)	58			
	@ 60 Hz	dB(a)	58			

* Neutral is required

** Higher pressure available upon request

Technical modifications reserved

Translations					
English	German	French	Spanish	Dutch	Danish
Voltage	Spannung	Voltage	Voltaje	Voltage	Spænding
Frequency	Frequenz	Fréquence	Frecuencia	Frequentie	Frekvens
Motor HP	Motor HP	Moteur CV	Motor CV	Motor HP	Motor HK
Displacement	Ansaugleistung	Débit	Aire aspirado	Capaciteit	Ydelse
Max. pressure	Max. Druck	Pression de service max.	Presión de régimen máx.	Max. druk	Max. arbejdstryk
Max. current	Stromverbrauch	Consommation	Corriente máxima	Max. stroom	Strømförbrug
Tank size	Behältervolumen	Volume réservoir	Volumen de tanque	Tankvolume	Beholderstørrelse
Weight	Gewicht	Poids	Peso	Gewicht	Vægt
Dimensions (l x w x h)	Abmessungen (l x b x h)	Dimensions (l x p x h)	Dimensiones (l x a x h)	Afmetingen (l x w x h)	Dimensioner (l x b x h)
Noise level	Schallemissionen	Niveau sonore	Nivel de ruido	Geluidsniveau	Lydniveau
Pumping time	Pumpzeit	Temps de refoulement	Tiempo de bombeo	Pomptijd	Oppumpningstid
Higher pressure available upon request	Höhere Druck lieferbar	Pression supérieure sur demande	Presión mayour sobre demanda	Hogere druk op aanvraag	Højere tryk kan leveres
Neutral is required	Null-leiter ist erforderlich	Neutre nécessaire	Neutro necesairo	Neutraal noodzakelijk	N-leder kræves
Technical modifications reserved	Technische Änderun- gen vorbehalten	Droits réservés pour modifications techniques	Reservamos el derecho a cambiar estas especificaciones técnicas sin previo aviso	Technische wijzigingen voorbehouden	Ret til ændringer forbeholdes



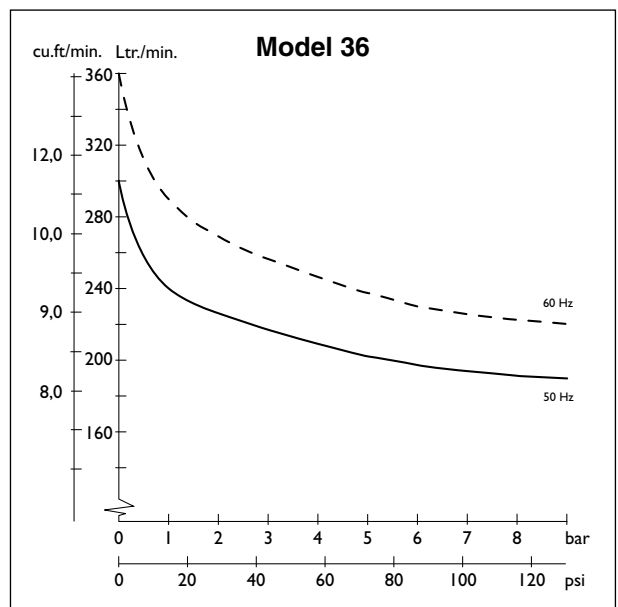
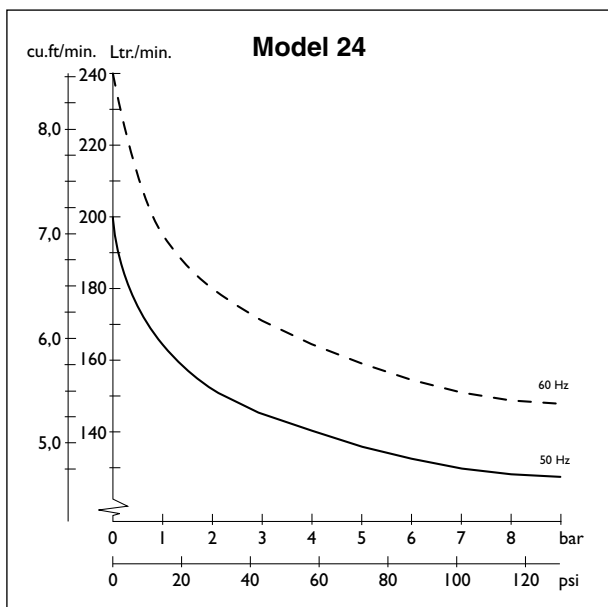
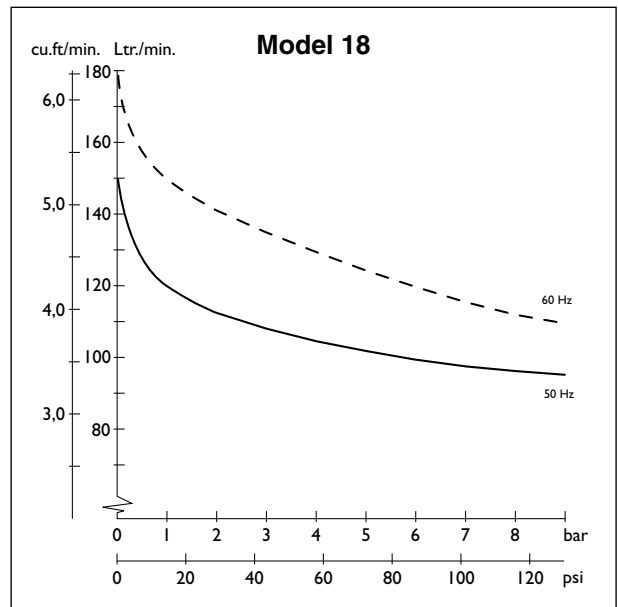
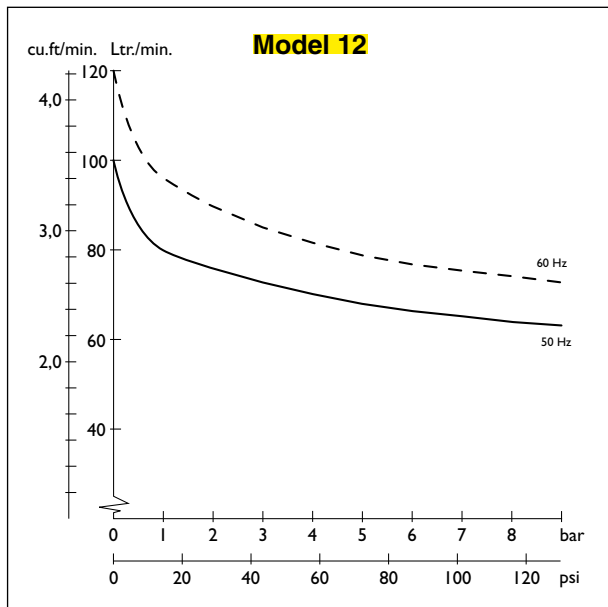
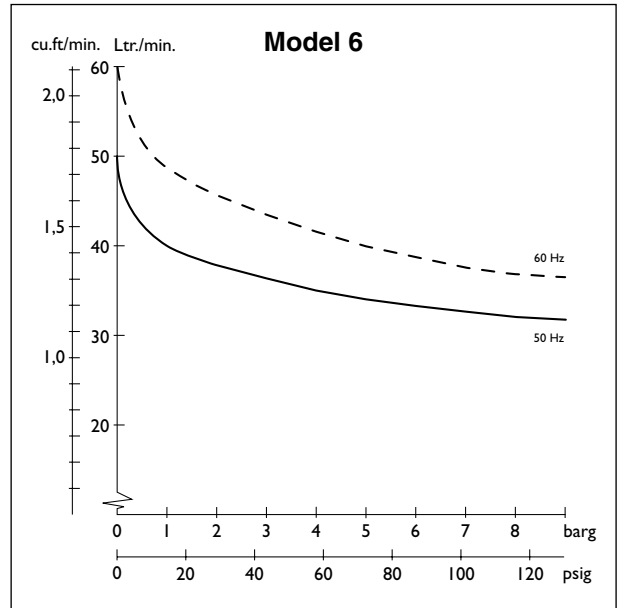
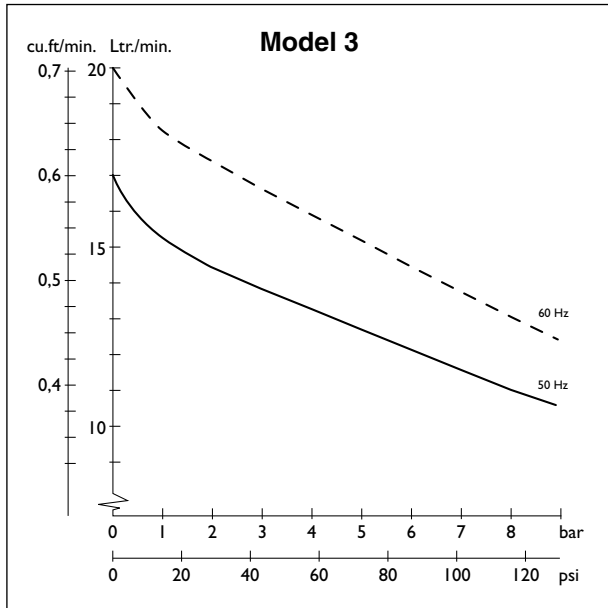







Performance



Electrical diagram for model 12

SPECIFICATION

Motorspec.: 220-240V~50-60Hz - 2,9A
115V~60Hz - 6,2A

-  : Earth
-  : Motor protection
-  : Lamp
-  : Capacitor
-  : Starting relay
-  : Auto drain timer
-  : Solenoid valve
-  : Fan 230V/0.2A/33W
115V/0.2A/24W
-  : Hourcounter 230V/0.03A
120V/0.03A
-  : Suppressor
-  : Extra features

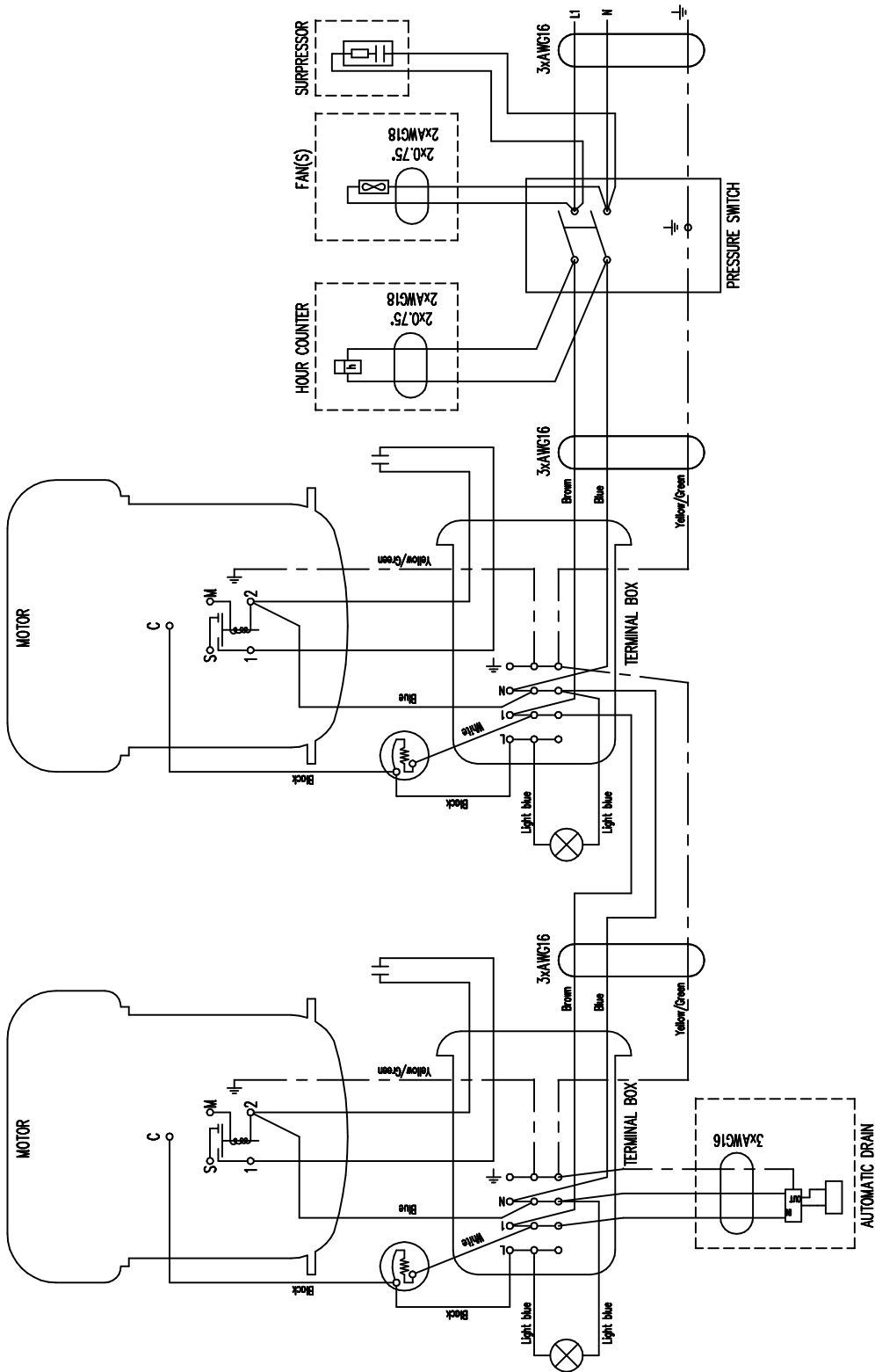

6070210

Spare parts

3010099	Receiver 4l without inspection plug CE, silver
3050099	Receiver 4l with inspection plug CE, silver, internally coated
3210095	Receiver 15l with inspection plug ASME, silver
3210099	Receiver 15l with inspection plug, CE, silver, fluid in nozzle
3410092	Receiver 25l with inspection plug, ASME, silver
3410099	Receiver 25l with inspection plug, CE, silver
3512097	Receiver 40l with inspection plug, CE/ASME, silver
3695298	Receiver 150l with inspection plug, CE, silver
4070500	Activated carbon filter DH AC-0003G
4071000	Filter 5um w/manual drain
4071020	Regulator R07-280-RNMG, 10 bar
4071030	Filter regulator 5um w/manual drain
4071055	Filter 0.01um w/manual drain
4071080	Lubricator L07-220-MPMG
4110000	Rapid coupler 1/4" external thread CEJN
4120000	Nipple 1/4"
4130000	Hose tail nipple 1/4" f/rapid coupler
4210000	Trolley f/6-10/15/25
4211000	Trolley f/6-4/3-1.5
4310000	Blow gun black
4311000	Blow gun black f/inflators
4380000	Ball inflator
4381000	Bicycle inflator
4382000	Car tyre inflator
4383000	Hose clamp 8-12 mm
4410000	PVC air hose 1/4"
4430000	Recoil air hose 1/4" 7.5m black
4520000	Overload protector f/6 motor 230V
4521000	Overload protector f/6 motor 120V
4522001	Overload protector f/3 motor 230V (new)
4522201	Overload protector f/3 motor 120V (new)
4522500	Overload spring f/6 motor
4523000	Starting relay 230V f/6 motor
4524000	Starting relay 120V f/6 motor
4526001	Starting relay f/3 motor 230V (new)
4526201	Starting relay f/3 motor 120V (new)
4526500	Terminal box compl. f/3 and 6 motors
4526600	Cover f/terminal box f/3 and 6 motors
4527000	Fastening spring f/3 and 6 motors
4528000	Bolt f/top bearing f/6 motor
4529000	Top bearing f/6 motor
4545000	Cover f/6 motor
4546000	Gasket f/cover f/6 motor
4547000	Pressure pipe f/6 motor (incl. gasket)
4548000	Gasket f/pressure pipe f/6 motor
4549000	Bolt f/pressure pipe f/6 motor
4550000	Copper washer f/6 motor
4551000	Suspension spring f/6 motor
4555000	Cylinder head f/6 motor
4556000	Bolt f/cylinder head f/6 motor

4560100	Casing bottom f/3 motor 230V silver (new)
4561000	Casing bottom f/6 motor silver
4571000	Rib cover f/6 motor, silver
4574300	Rib cover f/3 and 4 motors silver
4610201	Cylinder head f/3 motor (new)
4610501	Spring w/bushing f/3 motor (new)
4610601	Top bearing f/3 motor (new)
4611301	Cover f/terminal board f/3 motor (new)
4611350	Bracket f/terminal board f/3 motor (new)
4611360	Bracket f/klixon f/3 motor (new)
4646000	Gasket f/cover (= 4548000)
4649500	Bolt f/safety valve f/3 motor
4656000	Bolt f/cylinder head f/3 motor
4750000	Control lamp 230V
4750200	Control lamp 120V
5030000	Pressure switch MDR 2/11 compl.
5033000	Pressure switch MDR 21/11 w/unloader
5035000	Pressure switch MDR 2/11 w/unloader
5075010	Pressure switch MDR 21/11 UL compl.
5075100	Pressure switch MDR21/11 UL complete w/unloader
5085000	Pressure switch MDR 4S/11 compl.
5130000	Gauge 40 0-16 bar 1/8" down
5210000	Capacitor start 70uF
5230000	Capacitor start 160uF UL
5320226	Handle, multi complete
5340001	Handle f/6-15/6-25 complete
5410000	Oil level glass compl.
5410000	Oil level glass compl.
5412000	Intake filter f/6 motors, complete
5414000	Oil inlet screw w/gasket
5414500	Non return valve
5416000	Safety valve 10 bar / 145 psi
5416200	Safety valve 16 bar / 232 psi
5416200	Safety valve 16 bar / 232 psi
5418000	Drain cock 1/4" 4l
5419500	Drain cock 1/4" 15l
5420000	Drain cock 1/4" 25l
5421001	Drain cock 1/4" 40l (new)
5425000	Distributor f/non return valve compl.
5425000	Distributor f/non return valve compl.
5425500	Safety valve TÜV 10 bar
5426500	Safety valve TÜV 16 bar
5427000	Connecting piece 1/4"
5429000	Adaptor 5-way compl.
5429100	Adaptor 4-way compl.
5429500	Adaptor 2-way compl.
5451400	Fan compl. 120V 120x120mm
5451500	Fan compl. 230V 120x120mm
5453000	Fan guard 120x120
5470251	Spare parts kit f/replacement of valve plate f/3 motor (new)
5470300	Spare parts kit f/replacement of valve plate f/6 motor

5512000	Label "Min-Max"
5610000	Oil SJ-27 in 0.5l bottle
5612300	Drain bottle 1 l multi supplied separately incl. bracket for pipe mounting and magnet
5825000	Spring f/pressure control valve
5940000	Plastic insulation f/electric equipment
5950000	Plastic slide f/electric equipment
5960000	Cable relief
6214000	Copper washer Ø10xØ6x1 mm
6221000	Gasket f/pressure control valve
6235000	Gasket f/oil filling
6241800	O-ring f/1" plug - 32x5 mm
6244000	O-ring f/rib cover 6 motor
6244200	O-ring f/rib cover 3/4 motor
6245800	O-ring Ø47x5 f/1 1/2" plug
6246000	O-ring f/2" plug
6250000	Socket 25 mm black
6252010	Socket f/handle 3-1.5/6-4 Ø22
6253000	Rubber base f/handle Ø25x30 M8x8
6253200	Rubber base f/3-4000 models
6271000	Rubber grommet f/6 motor
6272000	Rubber grommet f/3-4 motor
6290200	Plastic handle black Ø22 mm
6312000	Bolt M8x35 FZB
6313200	Bolt M6x30 FZB
6317000	Nut M12 DIN934-8
6320200	Counter nut M8 flat FZB
6330000	Screw CHJ M4x5 FZB
6338000	Unbraco boltUNF 10-32 3/4"
6340500	Unbraco plug 1/8"
6341900	Unbraco bolt M6x16 FZB
6341950	Unbraco bolt M6x25 FZB
6350000	Washer ø23x11.5x1.5 FZB
6351000	Clamp f/electrical equipment
6356600	Washer 3/16" x 30 mm 4 motor
6357800	Washer Ø28.5 x Ø13 x 1.5 FZB
6372700	Lock nut M8 FZB
6413000	Flex hose 1/8" 13 (15) cm
6417000	Flex hose 1/8" 17 (19) cm
6420000	Flex hose 1/8" 20 (22) cm
6426000	Flex hose 1/8" 26 (28) cm
6433000	Flex hose 1/8" 33 (35) cm
6439000	Flex hose 1/8" 39 (41) cm
6450000	Flex hose 1/8" 50 (52) cm
6463000	Flex hose 1/8" 64 (66) cm
6463400	Flex hose 1/8" 80 (82) cm
6463700	Flex hose 1/8" 110 (112) cm
6960500	Spacer 17 mm
6961000	Spacer 23.3 mm (Ø11x1 mm)
6961200	Spacer 27 mm
6961500	Spacer f/transportation tap 4 motor
6973080	Unloader valve w/16.4 mm needle
6991800	Gasket 12x22x7 mm
7012000	Piston f/safety valve
7023000	Hose tail nipple 1/4"

7024000	Double nipple 1/4" L= 26 mm
7070500	Connection piece f/non-return valve model 12
7070600	Connection piece f/non-return valve model 12-25
7071000	T-piece 1/8"
7071400	T-piece Condor
7071400	T-piece Condor
7080010	Distributor 6 way f/18-40
7084000	Adaptor f/36-90
7110000	Screw f/pressure control valve
7140000	Housing f/pressure control valve
7156000	Extension piece f/cock short
7156100	Extension piece f/cock long
7157001	Extension piece w/through 1/4"
7164200	Cross connector
7164900	Plug 1" f/inspection
7166033	Plug 1 1/2" f/inspection ASME
7166800	Plug 2" galvanized
7172800	Spacer f/600-40/50B
7172820	Spacer f/2x600
7180000	Elbow 1/4" int./ext. KRG
7181002	Elbow 1/4" x 1/4" f/outlet
7190000	Elbow 1/8"
7190000	Elbow 1/8"
7525000	Hose tail f/coupling nut 1/4"
7525000	Hose tail f/coupling nut 1/4"
7525000	Hose tail f/coupling nut 1/4"
7525000	Hose tail f/coupling nut 1/4"
7525000	Hose tail f/coupling nut 1/4"
7562000	Nipple f/pressure control valve
7566000	Bushing 1/4" x 1/4"
7566200	Bushing 1/4" x 1/4" L = 35 mm
7567100	Bushing 1/2" x 1/4"
7573000	Nut f/rib cover 6 motor
7573500	Nut f/rib cover 3 motor
7575000	Coupling nut 1/4"
7575000	Coupling nut 1/4"
8105001	Bracket f/2xM3, 2xM4, 2xM6, 2xOF302, OF302, 1000, 2000 15-25l, painted
8110601	Motor foundation f/36-150, painted
8111501	Motor foundation f/12-40, painted
8111611	Motor foundation f/3x6, 4x3, 4x4, 4xOF302, 4x6, 2x1000, 2x2000-40, painted
8132000	Mounting bracket f/fan

Spare parts model 12-25

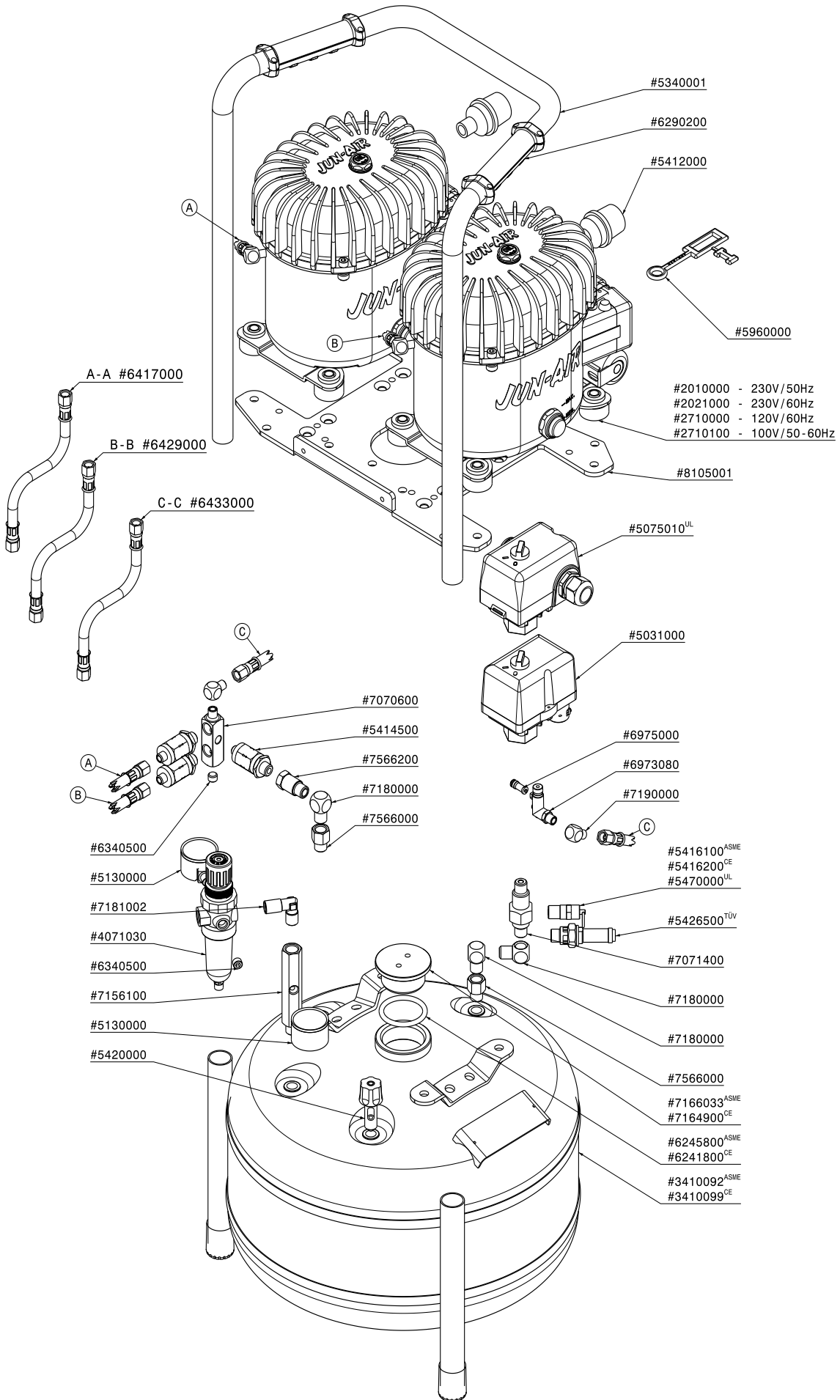

Accessories

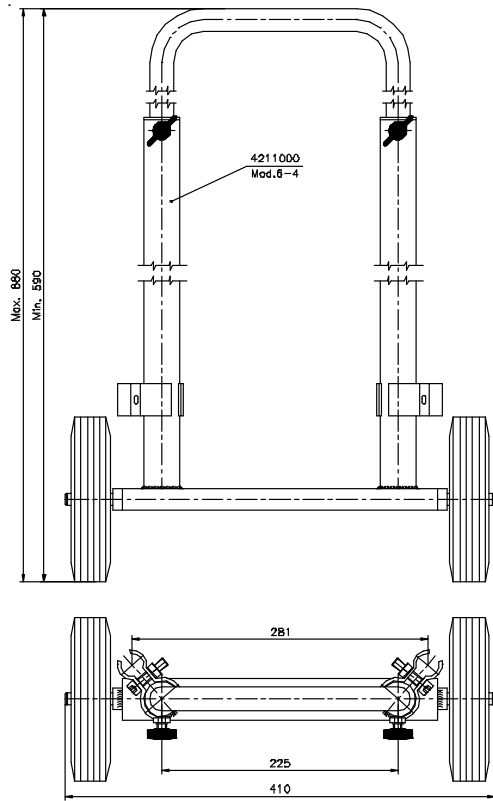

0991040

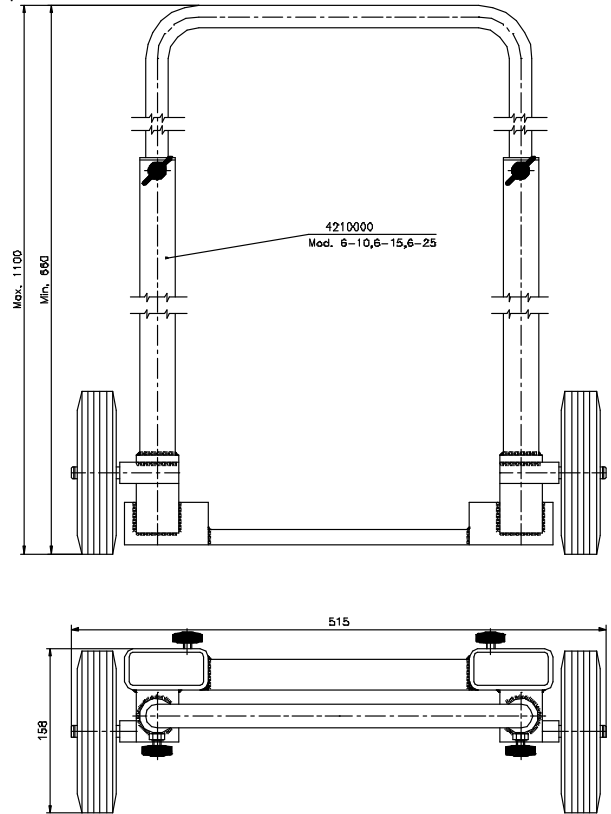

0991041

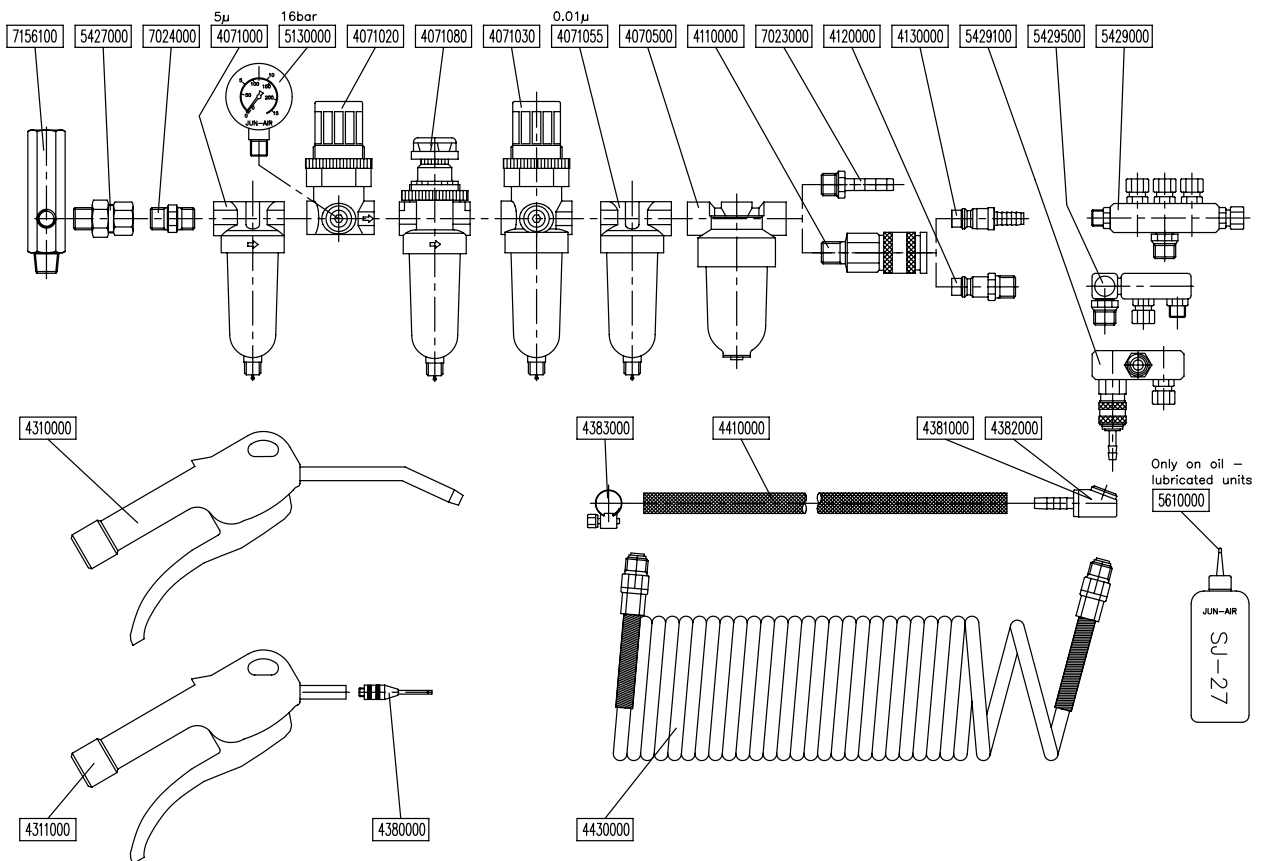

0015900

Figures

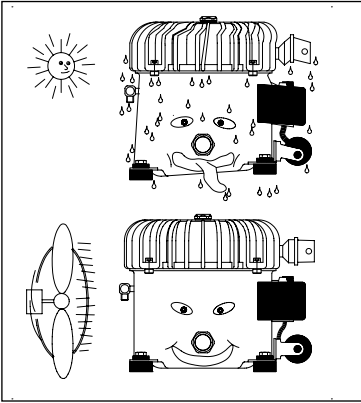

Fig. 1

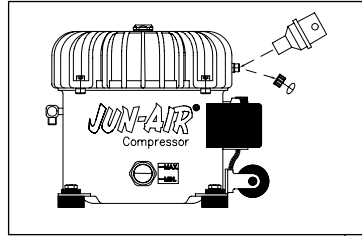

Fig. 2

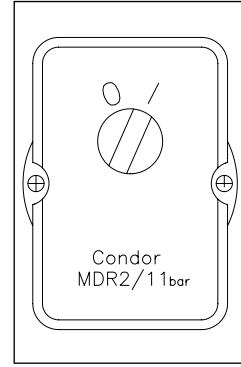

Fig. 3

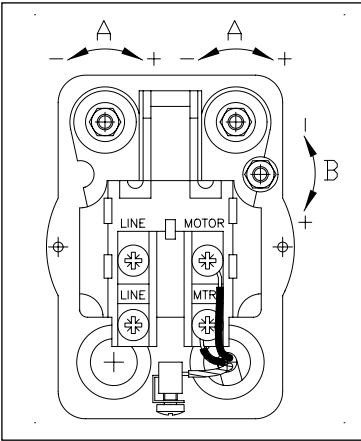

Fig. 4

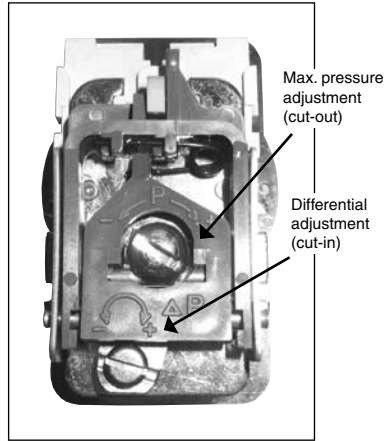

Fig. 4a

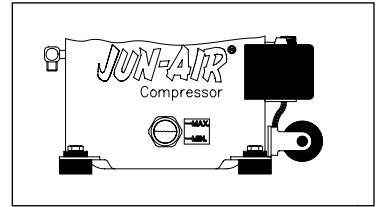

Fig. 5

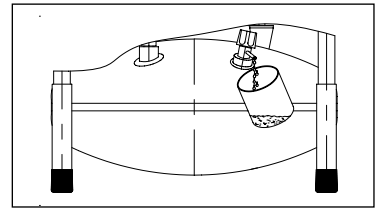

Fig. 6

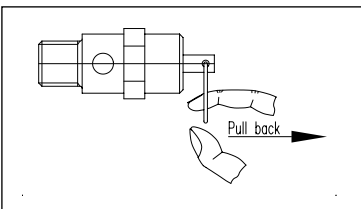

Fig. 7

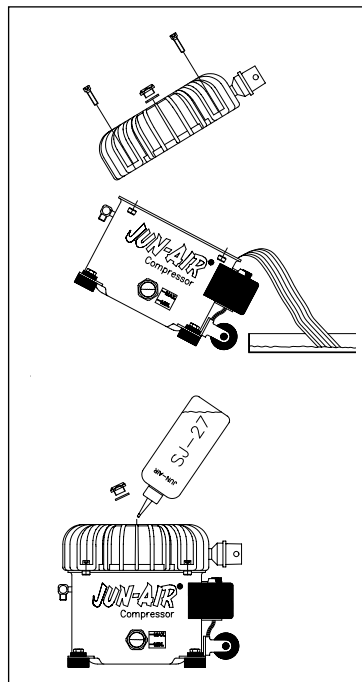

Fig. 8

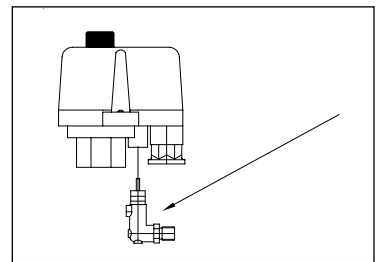

Fig. 9

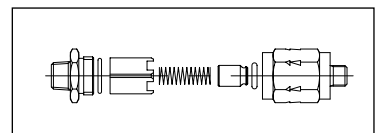

Fig. 10

JUN-AIR[®]

P.O. Box 97
Benton Harbor,
Michigan 49023-0097
USA

www.jun-air.com

Phone: 269-934-1216
Fax: 269-927-5725
E-mail: jun-air@idexcorp.com

GAST

A UNIT OF IDEX CORPORATION

IDEX
IDEX CORPORATION