

EX

700 - 1000 - 1500

1000 RT - 1500 RT

EXB 1000 - 1500

EXB 1000 - 1500 RT



Installation and user manual

English

Français

Deutsch

Italiano

Español

Nederlands

Русский

Pulsar Series

EAT•N

Powering Business Worldwide

EX

700 - 1000 - 1500

1000 RT - 1500 RT

EXB 1000 - 1500

EXB 1000 - 1500 RT



Installation and user manual

Pulsar Series

EATON

Powering Business Worldwide

Introduction

Thank you for selecting an EATON product to protect your electrical equipment.

The **EX** range has been designed with the utmost care.

We recommend that you take the time to read this manual to take full advantage of the many features of your **UPS (Uninterruptible Power System)**.

Before installing **EX**, please read the booklet on the required safety instructions. Then follow the indications in this manual.

To discover the entire range of EATON products and the options available for the **EX** range, we invite you to visit our web site at www.eaton.com or contact your EATON representative.

Environmental protection

EATON has implemented an environmental-protection policy. Products are developed according to an eco-design approach.

Substances

This product does not contain CFCs, HCFCs or asbestos.

Packing

To improve waste treatment and facilitate recycling, separate the various packing components.

- ▶ The cardboard we use comprises over 50% of recycled cardboard.
- ▶ Sacks and bags are made of polyethylene.
- ▶ Packing materials are recyclable and bear the appropriate identification symbol



Material	Abbreviation	Symbol number	
Polyethylene terephthalate	PET	01	
High-density polyethylene	HDPE	02	
Polyvinyl chloride	PVC	03	
Low-density polyethylene	LDPE	04	
Polypropylene	PP	05	
Polystyrene	PS	06	

Follow all local regulations for the disposal of packing materials.

End of life

EATON will process products at the end of their service life in compliance with local regulations.

EATON works with companies in charge of collecting and eliminating our products at the end of their service life.

Product

The product is made up of recyclable materials.

Dismantling and destruction must take place in compliance with all local regulations concerning waste.

At the end of its service life, the product must be transported to a processing centre for electrical and electronic waste.

Battery

The product contains lead-acid batteries that must be processed according to applicable local regulations concerning batteries.

The battery may be removed to comply with regulations and in view of correct disposal.

Pictograms



Important instructions that must always be followed.



Information, advice, help.



Visual indication.



Action.



Audio signal.

In the illustrations on the following pages, the symbols below are used:



LED off



LED on



LED flashing

Contents

1. Presentation	
1.1 Standard positions	6
Tower position	6
Rack position	6
1.2 Rear panels	7
EX 700 / 1000 / 1500	7
EX 1000 RT / 1500 RT	7
EX EXB (optional battery module)	7
EX EXB RT (optional battery module)	8
1.3 Control panel	8
2. Installation	
2.1 Unpacking and contents check	9
2.2 Installation of the RT model in tower position	10
2.3 Installation of the RT model in a rack	10
2.4 Communication ports	11
Connection of RS232 or USB communication port (optional)	11
Installation of the communication cards (optional)	12
2.5 Characteristics of the contact communication port	12
2.6 Connection with a FlexPDU (Power Distribution Unit) module	13
2.7 Connection with a HotSwap MBP module	13
HotSwap MBP-module operation	14
2.8 UPS connection without a FlexPDU or HotSwap MBP module	14
3. Operation	
3.1 Start-up and normal operation	15
3.2 Operation on battery power	15
3.3 Return of AC power	16
3.4 UPS shutdown	16
3.5 Using the UPS remote control functions	16
4. Access to measurements and personalisation data	
4.1 Display menus arrangement	18
4.2 Access to measurements	18
4.3 Personalisation using the control panel	18
5. Maintenance	
5.1 Troubleshooting	20
Troubleshooting a UPS equipped with the HotSwap MBP module	21
5.2 Battery-module replacement	21
Safety recommendations	21
Battery-module removal	21
Mounting the new battery module	23
5.3 Maintenance on a UPS equipped with the HotSwap MBP module	24
5.4 Training centre	25
6. Appendices	
6.1 Technical specifications	26
6.2 Glossary	27

1. Presentation

1.1 Standard positions

Tower position

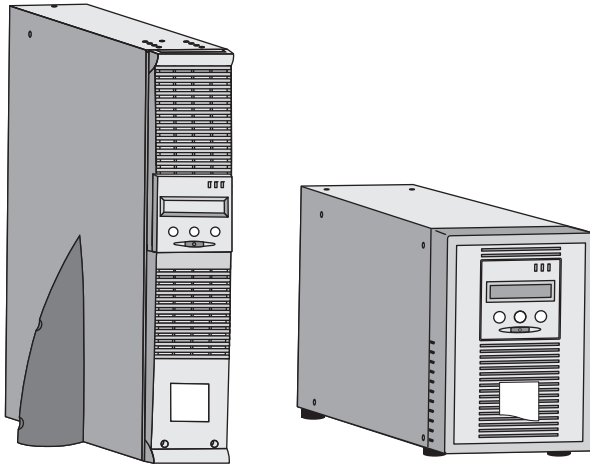

Dimensions (H x W x D) in mm	
EX 700	242 x 153 x 440
EX 1000	242 x 153 x 440
EX 1000 RT	86,5 x 438 x 483
EX 1500	242 x 153 x 490
EX 1500 RT	86,5 x 438 x 483
EX EXB	242 x 153 x 440
EX EXB RT	86,5 x 438 x 483

Weights in kg	
EX 700	12,5
EX 1000	15
EX 1000 RT	18
EX 1500	18
EX 1500 RT	20,5
EX EXB	21
EX EXB RT	24,5

Rack position

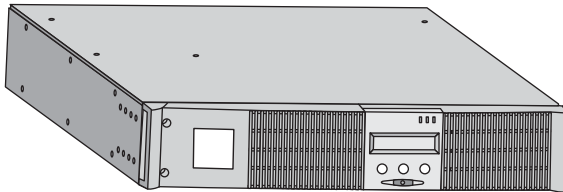

1.2 Rear panels

EX 700 / 1000 / 1500

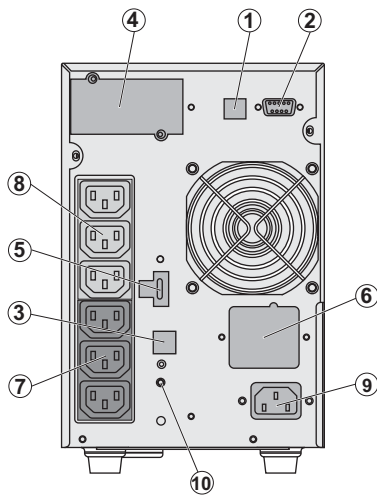

- (1) USB communication port
- (2) RS232 and dry contacts communication port
- (3) Connector for automatic recognition of a battery EXB module (except on **EX 700**)
- (4) Slot for optional communication card
- (5) Connector for remote ON/OFF and RPO (Remote Power Off) control
- (6) Connector for battery EXB module
- (7) Group of 3 programmable outlets for connection of equipment
- (8) Group of 3 outlets for connection of equipment
- (9) Socket for connection to AC-power source
- (10) LED (SWF) indicating distribution system phase/neutral reversal

EX 1000 RT / 1500 RT

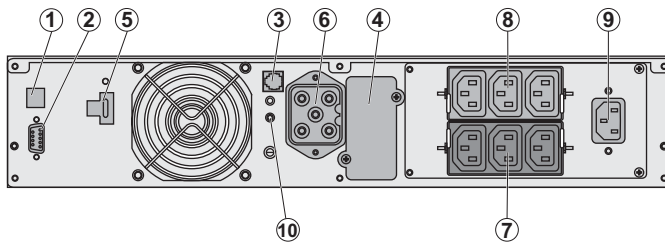

EX EXB (optional battery module)

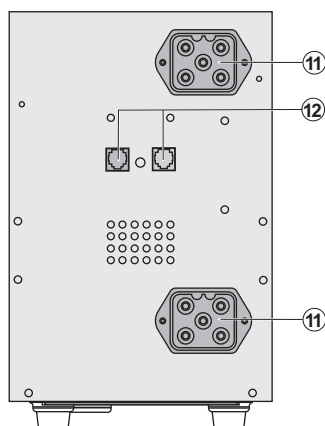

- (11) Connectors for battery modules (to the UPS or to the other battery modules)
- (12) Connectors for automatic recognition of battery modules

EX EXB RT (optional battery module)

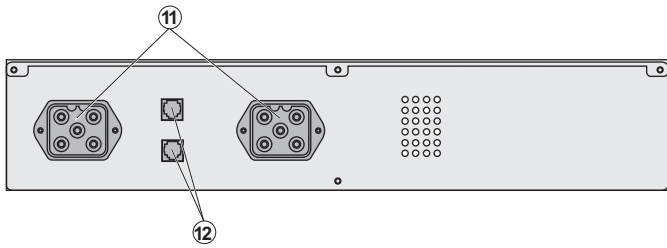

1.3 Control panel

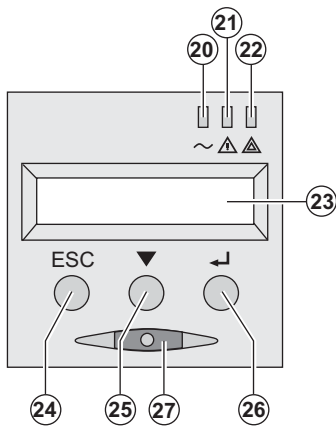

- (20) Load protected LED
- (21) Downgraded operation LED
- (22) Load not protected LED
- (23) Alphanumeric display
- (24) Escape (cancel) button
- (25) Scroll button
- (26) Enter (confirm) button
- (27) ON/OFF button for UPS and outlets

2. Installation

2.1 Unpacking and contents check

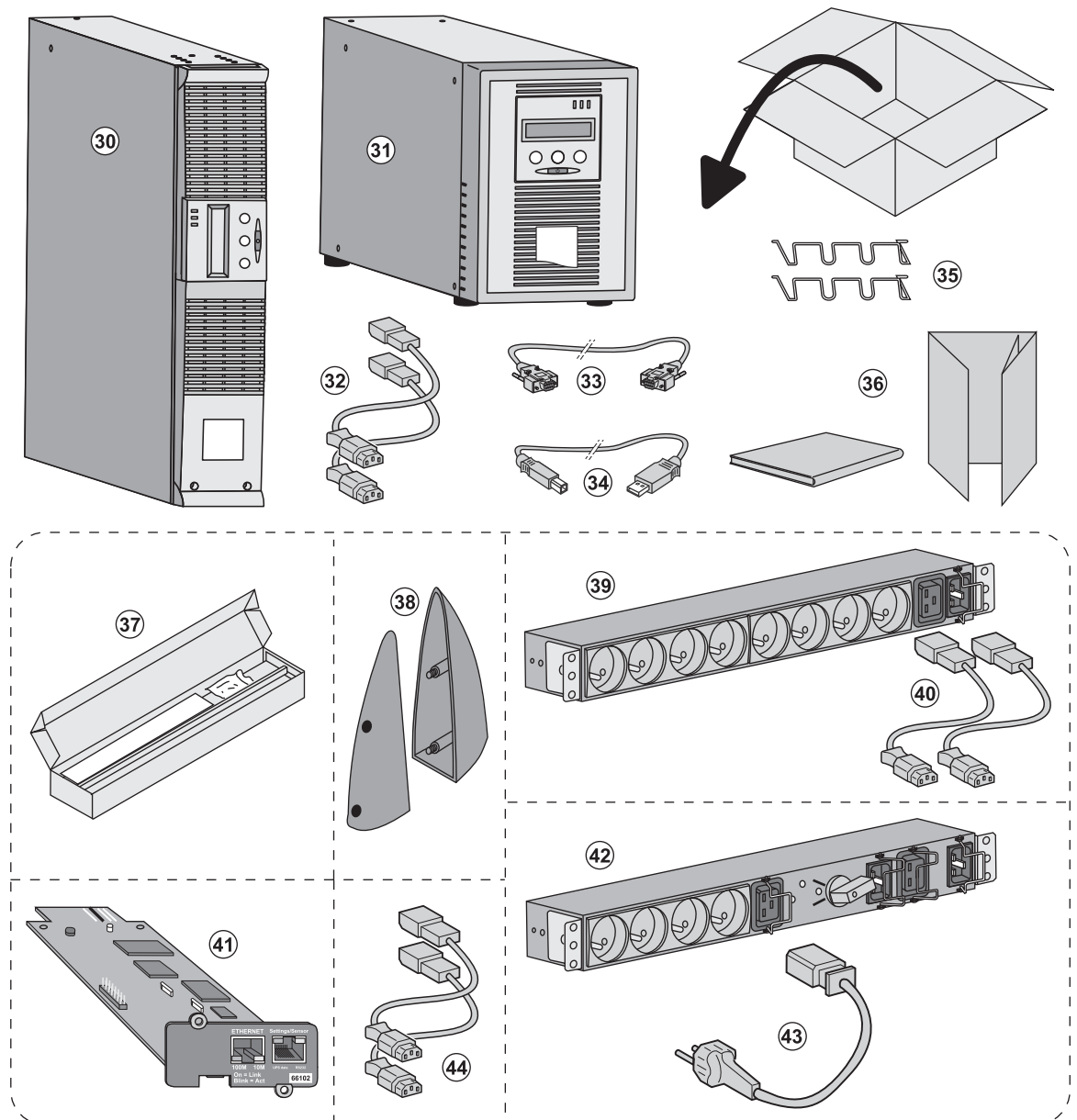

(30) EX 700, 1000, 1500

(31) EX 1000 RT, 1500 RT

(32) 2 connection cables for the protected equipment

(33) RS232 communication cable

(34) USB communication cable

(35) Securing system for equipment power cords

(36) Documentation

Elements supplied depending on the version or optional

(37) Mounting kit for 19-inch bays

(38) 2 supports for the upright position (RT model only)

(39) FlexPDU module (optional)

(40) Connection cable between **FlexPDU** module and UPS

(41) NMC communication card (optional)

(42) HotSwap MBP module (optional)

(43) Connection cables between **HotSwap MBP** module and AC-power source

(44) Connection cables between **HotSwap MBP** module and UPS



Packing materials must be disposed of in compliance with all local regulations concerning waste. Recycling symbols are printed on the packing materials to facilitate sorting.

2.2 Installation of the RT model in tower position

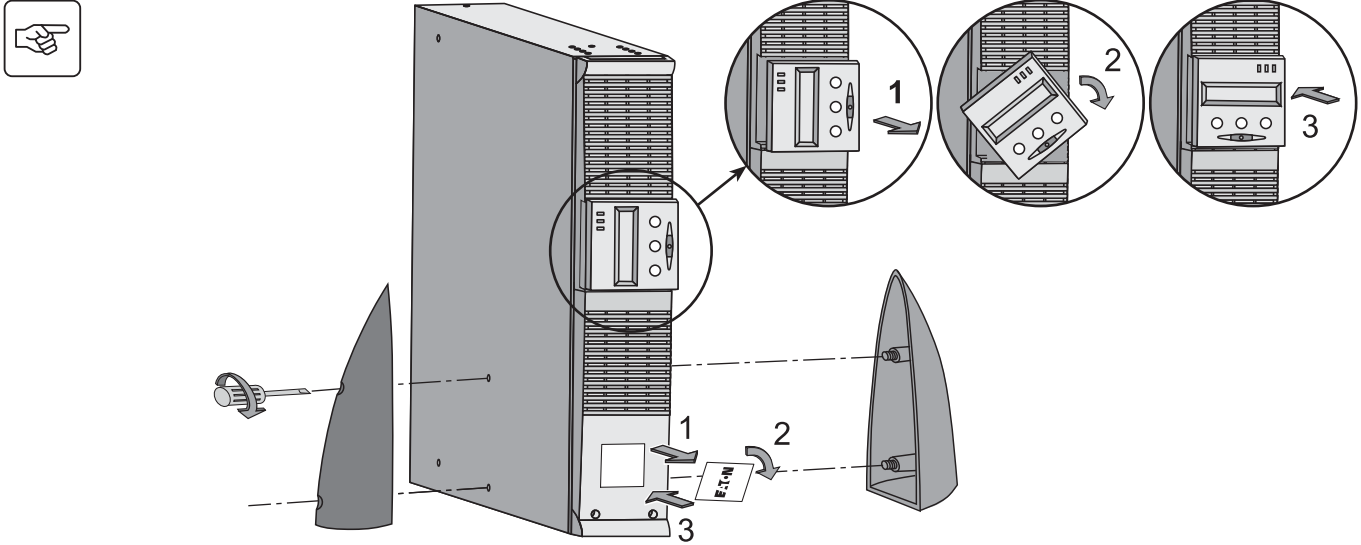

2.3 Installation of the RT model in a rack

It is advised to install the battery EXB module(s) at the lowest position in the rack, then install the UPS above.



Follow steps 1 to 4 for module mounting on the rails.

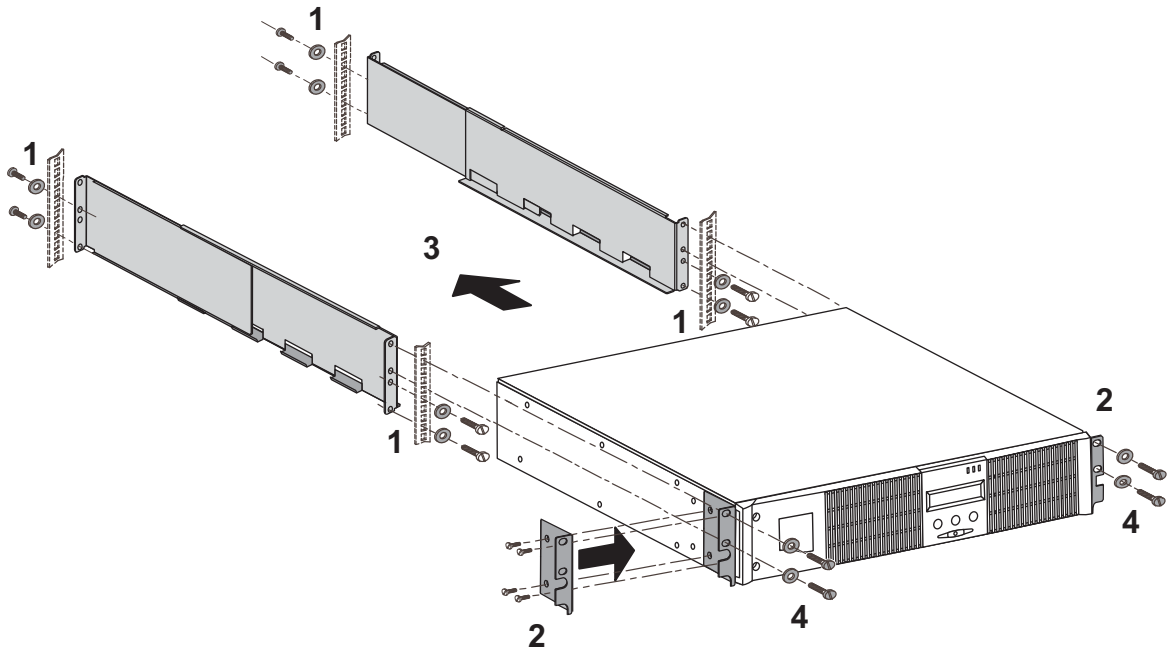

The rails and necessary hardware (37) are supplied by EATON.

2.4 Communication ports

Connection of RS232 or USB communication port (optional)



The RS232 and USB communication ports cannot operate simultaneously.

Tower model

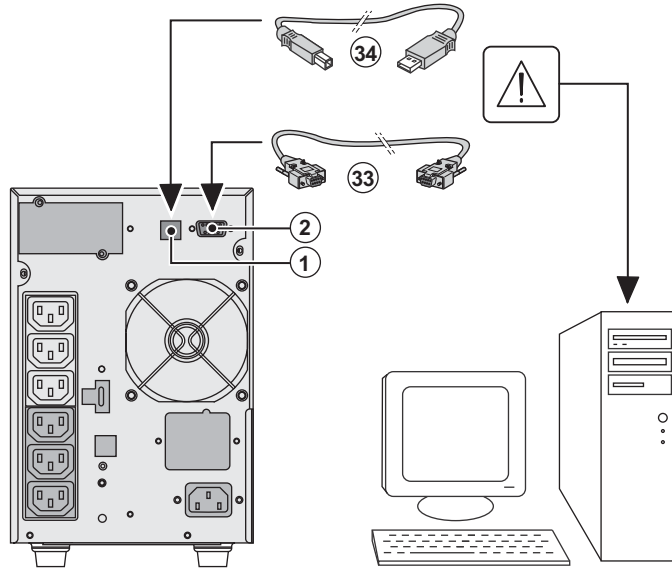

1 - Connect the RS232 (33) or USB (34) communication cable to the serial or USB port on the computer equipment.

2 - Connect the other end of the communication cable (33) or (34) to the USB (1) or RS232 (2) communication port on the UPS.

The UPS can now communicate with EATON power management software.



RT model

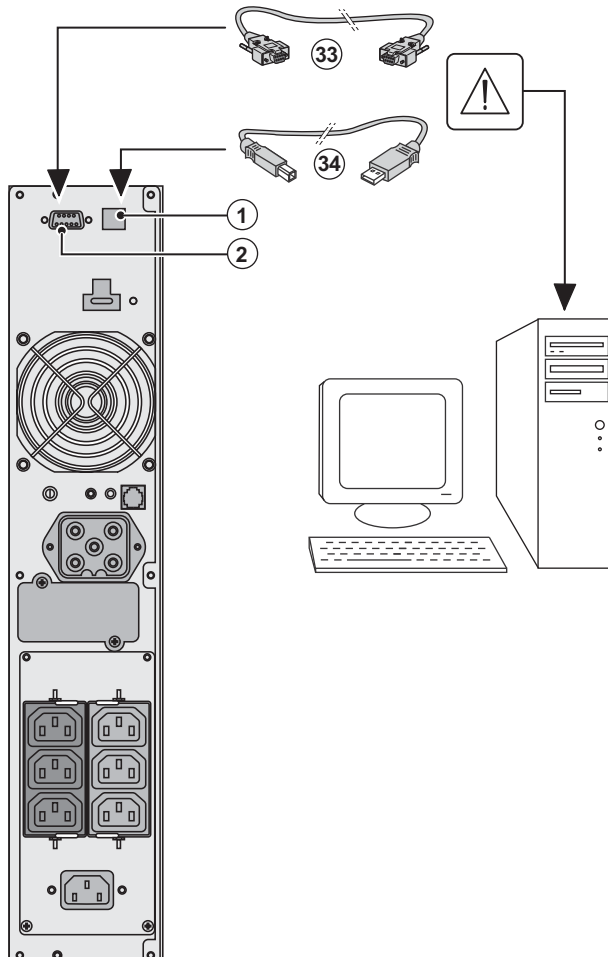

Installation of the communication cards (optional)



Tower model

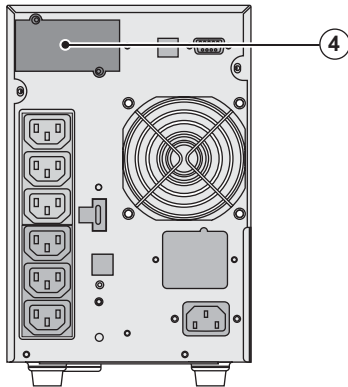

RT model

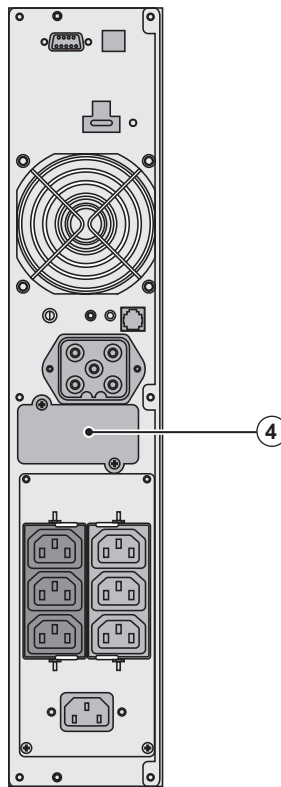

It is not necessary to shutdown the UPS before installing a communication card. **(4)**: Slot, with restricted access, for the communications-card.

- 1 - Remove the UPS cover **(4)** secured by screws.
- 2 - Insert the communication card in the slot.
- 3 - Put the UPS cover back in place using the screws.

2.5 Characteristics of the contact communication port (2)

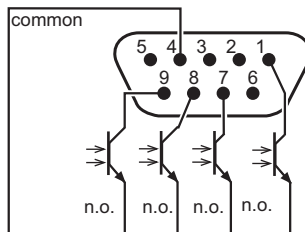

- ▶ Pin 2, 3, 5 and 6 : not used,
- ▶ Pin 1 : operation on automatic by-pass,
- ▶ Pin 4 : user common,
- ▶ Pin 7 : low battery,
- ▶ Pin 8 : load protected,
- ▶ Pin 9 : operation on battery.

n.o.: contact normally open.

When the status is active, the contact between the common (Pin 4) and the relevant information pin is closed.

Contact characteristics (optocoupler)

- ▶ Voltage: 48 V DC max,
- ▶ Current: 25 mA max,
- ▶ Power: 1.2 W.

2.6 Connections with a FlexPDU (Power Distribution Unit) module (optional)

RT model

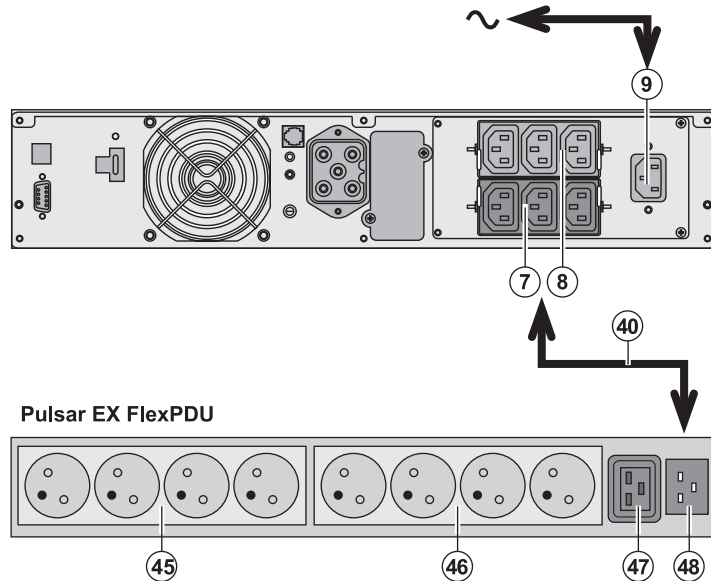

1 - Connect the UPS socket (9) to the AC-power source using the power cable from the equipments to be protected.

2 - Connect the input socket on the **FlexPDU** module (48) to the UPS outlet (7) or (8) using the cable (40) IEC 10A/16A supplied.

The cable and the connectors are marked in red.

3 - Connect the equipment to the outlets (45), (46) and (47) on the **FlexPDU** module. These outlets differ, depending on the version of the **FlexPDU** module.

4 - Fit the connection securing system that prevents the plugs from being pulled out accidentally.

2.7 Connections with a HotSwap MBP module (optional)

The **HotSwap MBP** module makes it possible to service or even replace the UPS without affecting the connected loads (**HotSwap** function).

RT model

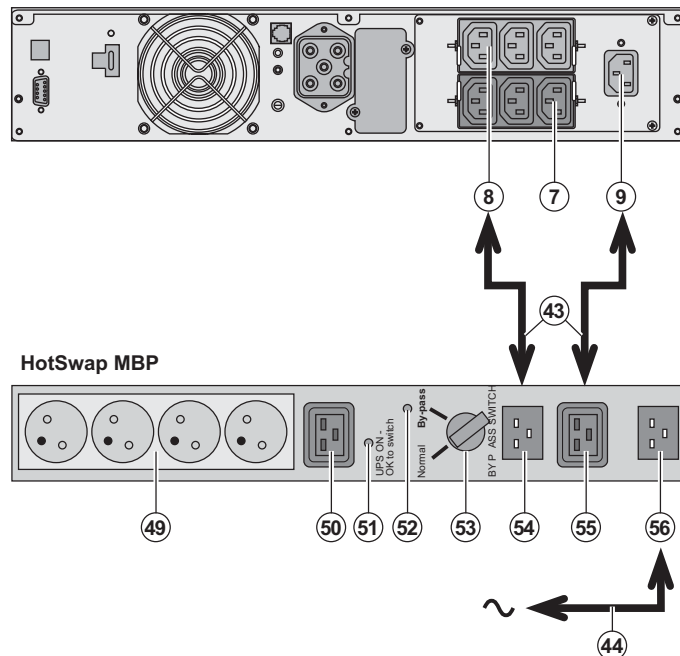

1 - Connect the input socket (56) on the **HotSwap MBP** module to the AC-power source using the cable (44) supplied.

2 - Connect the UPS input socket (9) to the "UPS Input" (55) on the **HotSwap MBP** module, using the cable (43) supplied. This cable and the connectors are marked blue.

3 - Connect the UPS outlet (8) to the "UPS Output" (54) on the **HotSwap MBP** module, using the cable (43) supplied. This cable and the connectors are marked red.

To power the **HotSwap MBP** module and to connect it to the UPS, it is necessary to use the 10A FR/DIN cable kit for **HotSwap MBP** (ref. 68439).

If the AC-power source socket is BS type, use the 10A BS cable kit **HotSwap MBP** (ref. 68440).

4 - Connect the equipment to the outlets (49) and (50) on the **HotSwap MBP** module. These outlets differ, depending on the version of the **HotSwap MBP** module.



Caution. Do not use UPS outlets (7) and (8) to supply equipment because use of switch (53) on the **HotSwap MBP** module would cut supply to the equipment.

HotSwap MBP-module operation

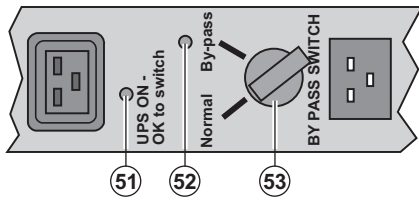

The **HotSwap MBP** module has a rotary switch (53) with two positions:
Normal - the load is supplied by the UPS,
Bypass - the load is supplied directly by the AC-power source.

UPS start-up with the HotSwap MBP module

- 1 - Check that the UPS is correctly connected to the **HotSwap MBP** module.
 - 2 - Set switch (53) to the Normal position.
 - 3 - Start the UPS by pressing the ON/OFF button (27) on the UPS control panel.
- The load is supplied by the UPS.
 LED (51) "UPS ON - OK to switch" on the **HotSwap MBP** module goes ON.

HotSwap MBP-module test

- 1 - Set switch (53) to the Bypass position and check that the load is still supplied.
- 2 - Set switch (53) back to the Normal position.

2.8 UPS connection without a FlexPDU or HotSwap MBP module



Check that the indications on the name plate located on the back of the UPS correspond to the AC-power source and the true electrical consumption of the total load.

Tower model

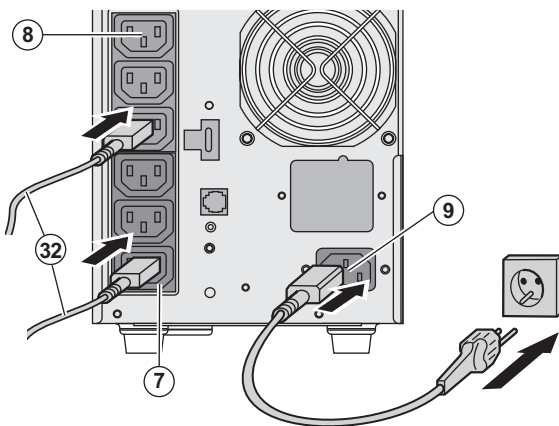

- 1 - Connect the UPS socket (9) to the AC-power source using the power cable from the equipments to be protected.
 - 2 - Connect the loads to the UPS using the cables (32).
- It is preferable to connect the priority loads to the 3 outlets marked (8) and the non-priority loads to the 3 outlets marked (7) that can be programmed in pairs (1 and 2).

To program the outlets, the EATON communications software is required.



RT model

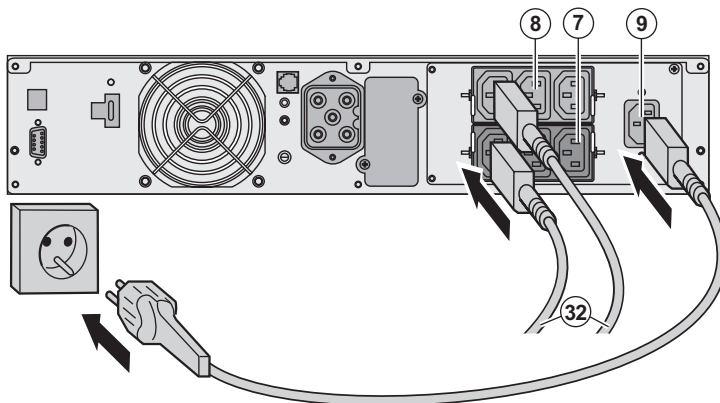

Note. The UPS charges the battery as soon as it is connected to the AC-power source, even if button (27) is not pressed.
Once the UPS is connected to the AC-power source, eight hours of charging are required before the battery can supply the rated backup time.

3. Operation

3.1 Start-up and normal operation



For the initial start, AC power must be present to detect any wiring errors. Subsequently, the UPS can start even if AC power is not present.

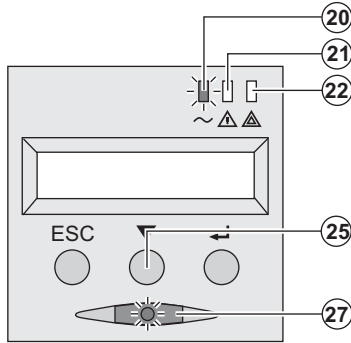

Press button (27) for approximately 1 second.

- ▶ The buzzer beeps once and all the LEDs go ON simultaneously.
- ▶ The buzzer then beeps twice during the self-test, then button (27) remains ON, indicating that the load outputs are supplied.

The connected devices are protected by the UPS.

▶ LED (20) is ON.

If LED (22) is ON, a fault has occurred (see the "Troubleshooting" section).

▶ During normal operation, the scroll button (25) may be used to read UPS measurements (AC input voltage, operating mode, battery capacity and UPS serial number).



UPS personalisation



If UPS personalisation is desired, it is advised to enter the personalisation mode at this time. This mode may be entered using the buttons on the control panel.

3.2 Operation on battery power

Transfer to battery power

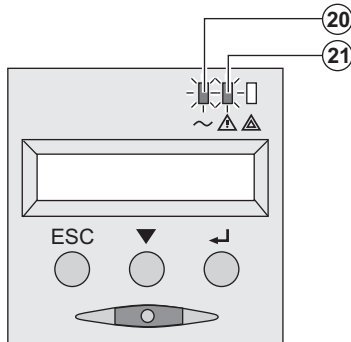

▶ The connected devices continue to be supplied by the UPS when AC power is no longer available. The necessary energy is provided by the battery.

▶ LEDs (20) and (21) go ON.

▶ The audio alarm beeps every ten seconds.

The connected devices are supplied by the battery.

The display indicates the remaining backup time.



Low-battery warning

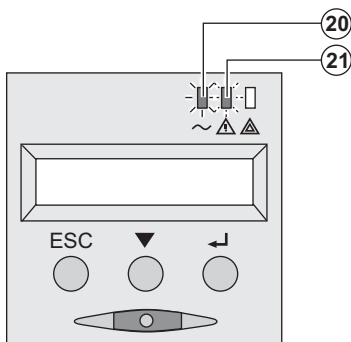

▶ LEDs (20) and (21) go ON.

▶ The audio alarm beeps every three seconds.

The remaining battery power is low.

Shut down all applications on the connected equipment because automatic UPS shutdown is imminent.



End of battery backup time



- ▶ All the LEDs go OFF.
- ▶ The audio alarms stops.



The UPS is completely shut down.

3.3 Return of AC power

Following an outage, the UPS restarts automatically when AC power returns (unless the restart function was disabled via UPS personalisation) and the load is again supplied.

3.4 UPS shutdown

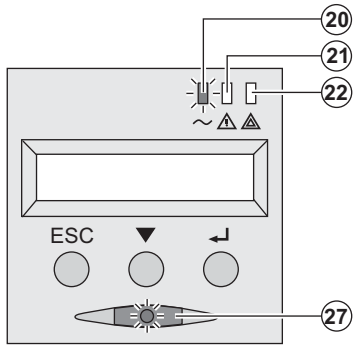

Press button (27) for approximately 2 seconds.

The devices connected to the UPS are no longer supplied.

3.5 Using the UPS remote control functions

EX has the choice of two remote control options.

- ▶ **RPO: Remote Power Off** allows a remote contact to be used to disconnect all the equipment connected to the UPS from the power supply.

Restarting the UPS requires manual intervention.

- ▶ **ROO: Remote ON/OFF** allows remote action of button (27).

These functions are obtained by opening a contact connected between the appropriate pins of connector (5) on the rear panel of the UPS (see diagram on following page).

RT model

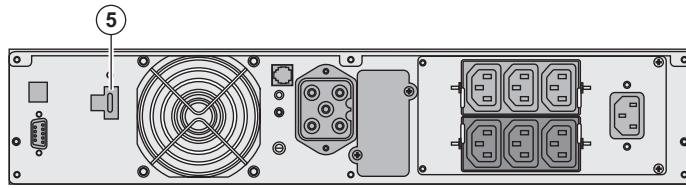

Tower model

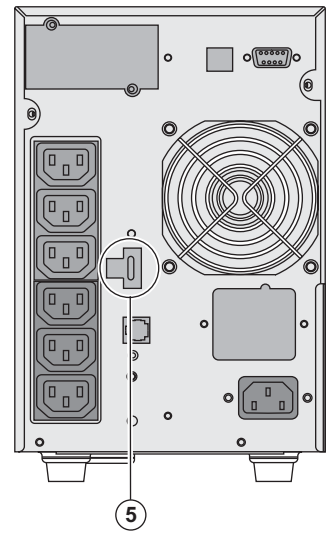

Remote control connection and test



- 1 - Check the UPS is shut down and the electrical supply network disconnected.
- 2 - Remove connector **(5)** by unfitting the screws.
- 3 - Connect a normally closed volt-free contact (60 Vdc / 30 Vac max, 20 mA max, 0.75 mm² cable cross section) between the two pins of connector **(5)**, see diagram.

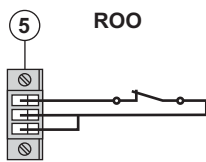

ROO

Contact open: shut down of UPS

Contact closed: start-up of UPS (UPS connected to the network and network energized)

Note: local On/Off control via button **(27)** has priority over the remote control order.

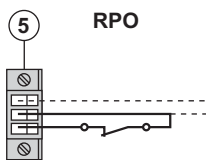

RPO

Contact open: shut down of UPS

To return to normal operation, deactivate the external remote shut down contact and restart the UPS using button **(27)**.

- 4 - Plug connector **(5)** into the back of the UPS.
- 5 - Connect and restart the UPS according to the previously described procedures.
- 6 - Activate the external remote shut down contact to test the function.



Warning: this connector must only be connected to SELV (Safety Extra Low Voltage) circuits

4. Access to measurements and personalisation data

4.1 Display menus arrangement

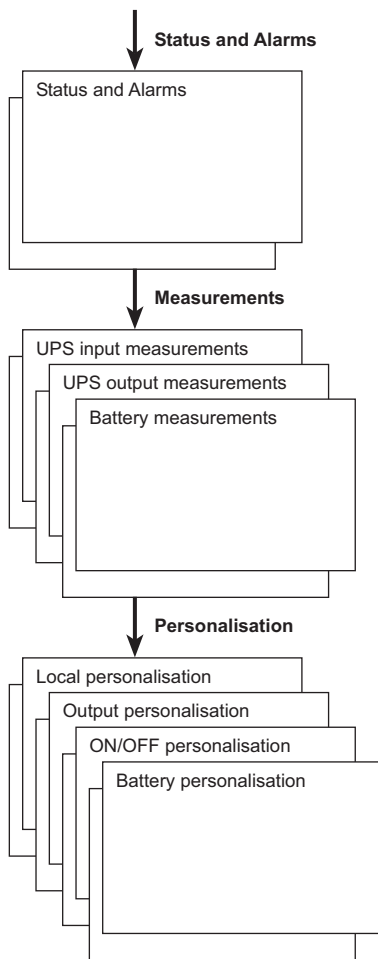

4.2 Access to measurements

Press the scroll button **(25)** to access any status conditions and alarms, then the measurements for voltage, current, frequency, power output and battery backup time.

4.3 Personalisation using the control panel

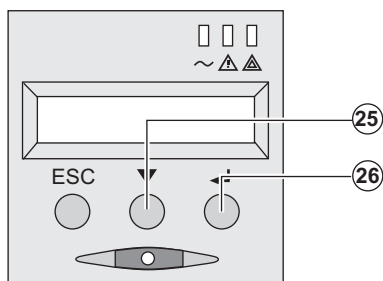

- ▶ Press the scroll button **(25)** several times until the personalisation menu is reached.
- ▶ Press the Enter button **(26)** to access the different possibilities.
- ▶ Finally, confirm the selection by pressing the Enter button **(26)** again.

Local personalisation

Function	Factory setting	Other available settings
Language	English	French, Spanish, German, Italian, Dutch
Audio alarm	Enabled	Disabled

Output personalisation

Function	Factory setting	Other available settings	Comments
Output voltage ⁽¹⁾	230 Volts AC	200/208/220/240/250 Volts AC	
Frequency converter ⁽¹⁾	Disabled	Enabled	The connected devices are never transferred to the bypass.
Output frequency ⁽¹⁾	Automatic selection	50 or 60 Hz	User selectable only if the frequency-converter function is enabled.
Transfer to the bypass AC input ⁽¹⁾	Bypass AC power must be within tolerances	Bypass AC power may be outside tolerances	
Overload level ⁽¹⁾	100%	30 / 50 / 70%	Alarm if threshold is overrun.

(1) These parameters may be modified only when the **UPS** is OFF.

ON/OFF personalisation

Fonction	Personnalisation usine	Autres choix	Commentaires
Start on battery power	Enabled	Disabled	
Automatic restart	Enabled	Disabled	The UPS restarts automatically when AC power returns.
Energy savings	Disabled	Enabled	When function enabled, battery shuts down when power drops to <5%.
Detection of phase/neutral inversion (SWF)	Disabled	Enabled	When function enabled, the UPS remains OFF if the system detects phase/neutral inversion.

Battery personalisation

Function	Factory setting	Other available settings	Comments
Battery test	Weekly test	No test / daily test / monthly test	
Low-battery warning	20%	0 to 100%	Adjustable in 1% steps.
Selection of the backup time	Automatic detection of number of battery modules	13 to 200 Ah	
Battery protection against excessive discharges	Enabled	Disabled	When function disabled, EATON warranty no longer applies.

5. Maintenance

5.1 Troubleshooting



If LED (21) or (22) is ON, a fault or an alarm has occurred.
Use the escape button (24) to stop the audio alarm.

	Indication	Diagnostic	Correction
1	The UPS does not start, the alphanumeric display indicates: COLD START NOK CHECK AC WIRING	The AC input power is not connected or is connected to the UPS output.	Check the UPS is correctly connected to the AC input power.
2	LED (22) is ON, the SWF LED (11) at the rear of the UPS is ON. The alphanumeric display indicates: SITE WIR. FAULT CHECK AC WIRING	Phase inversion on AC input power. The UPS does not start.	<ul style="list-style-type: none"> ▶ In an earthed-neutral system, to correct the wiring, disconnect and turn the AC-power outlet 180° (DIN-SCHUKO type) or call an electrician to modify the connections. ▶ For all other types of system, disable the detection function.
3	LED (22) is ON, the alphanumeric display indicates: NO BATTERY CHECK CONNECTION	The battery is incorrectly connected.	Check battery connections (see section 5.2, Battery-module replacement).
4	LED (22) is ON, the alphanumeric display indicates: BATTERY FAULT SERV REQUIRED	A fault is detected on the battery.	Replace the battery (see section 5.2, Battery-module replacement). Call the after-sales support department.
5	LED (21) is ON, the alphanumeric display indicates: OVERLOAD ALARM REDUCE LOAD	The load level exceeds the programmed overload level or UPS capacity.	Check the power drawn by the connected devices and disconnect any non-priority devices. Check the programmed overload level.
6	LED (22) is ON, the alphanumeric display indicates: LOAD UNPROTECTED OUTPUT OVERLOAD	The UPS is overloaded. Devices connected to the UPS are fed directly by the electrical network via the By-pass.	Check the power drawn by the connected devices and disconnect any non-priority devices.
7	LED (22) is ON, the alphanumeric display indicates: REDUCE LOAD RESTART UPS	After repetitive overloads, the UPS is locked in the By-pass position. Devices connected to the UPS are fed directly by the electrical network.	Check the power drawn by the connected devices and disconnect any non-priority devices. Shut down and restart the UPS to return to normal operation.
8	LED (22) is ON, the alphanumeric display indicates: OVERLOAD FAULT REDUCE LOAD	The UPS shut down automatically because of overload at the UPS output.	Check the power drawn by the connected devices and disconnect any non-priority devices.
9	LED (22) is ON, the alphanumeric display indicates: LOAD SHORT-CIRCU CHECK WIRING	The UPS shut down automatically because of a short-circuit at the UPS output.	Check the installation at the UPS output (wiring, fault equipment).
10	LED (22) is ON, the alphanumeric display indicates: INTERNAL FAULT SERV REQUIRED	A UPS internal fault has occurred. There are two possible situations: <ul style="list-style-type: none"> ▶ the load is still supplied, but directly with AC power via the bypass, ▶ the load is no longer supplied. 	Call the after-sales support department.
11	The alphanumeric display indicates: REMOTE POWER OFF RPO	Switching of the Remote Power Off (RPO) has led to the shut down of the UPS.	Replace the contact in the normal position, and press the ON/OFF button to restart.

Troubleshooting a UPS equipped with the HotSwap MBP module



	Indication	Diagnostic	Correction
12	The load is no longer supplied when the rotary switch (49) on the HotSwap MBP module is set to the Bypass position.	<ul style="list-style-type: none"> ▶ The protected devices are connected to the UPS output instead of to the HotSwap MBP module. ▶ The AC-power cord is connected to the UPS input instead of to the HotSwap MBP module. 	Check the wiring between the UPS and the HotSwap MBP module (see section 2.6).
13	The load is no longer supplied when the rotary switch (49) on the HotSwap MBP module is set to the Normal position.	<ul style="list-style-type: none"> ▶ The UPS is shut down. ▶ The wiring between the UPS and the HotSwap MBP module is not correct. 	<ul style="list-style-type: none"> ▶ Start the UPS. ▶ Check the wiring between the UPS and the HotSwap MBP module (see section 2.6).
14	The load is no longer supplied if AC-power fails.	<ul style="list-style-type: none"> ▶ The rotary switch (49) on the HotSwap MBP module is set to the Bypass position. ▶ The wiring between the UPS and the HotSwap MBP module is not correct. 	<ul style="list-style-type: none"> ▶ Set the rotary switch (49) on the HotSwap MBP module to the Normal position. ▶ Check the wiring between the UPS and the HotSwap MBP module (see section 2.6).

If a fault leads to UPS shutdown, press the ON/OFF button (27) to clear the fault.

5.2 Battery-module replacement

Safety recommendations

The battery can cause electrocution and high short-circuit currents. The following safety cautions are required before servicing the battery components:

- ▶ Remove watches, rings, bracelets and all other metal objects from the hands and arms,
- ▶ Use tools with an insulated handle.

Battery-module removal

RT model

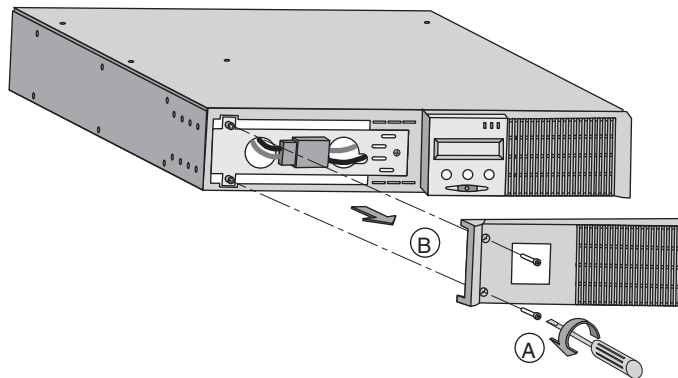

- A** - Unscrew the left-hand side of the front panel (two screws).
- B** - Remove the part.

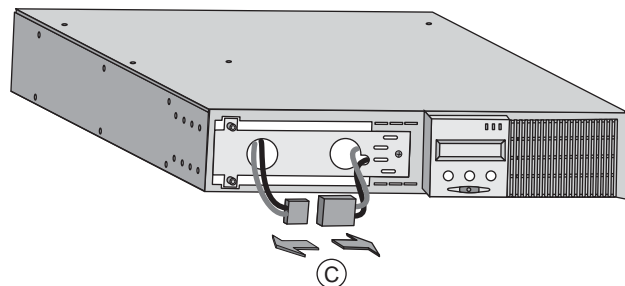

- C** - Disconnect the battery block by separating the two connectors (never pull on the wires).

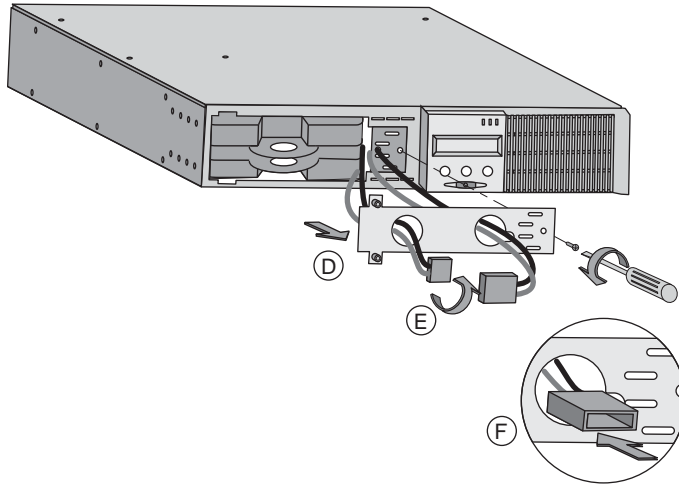

D - Remove the metal protection cover in front of the battery (two screws).
E - Turn the connector.
F - Pass the connector through the hole.

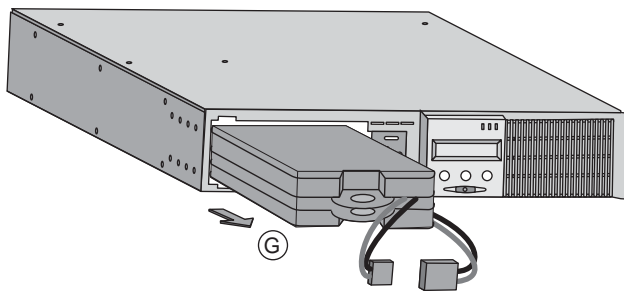

G - Pull the plastic tab to remove the battery block and replace it.

Tower model

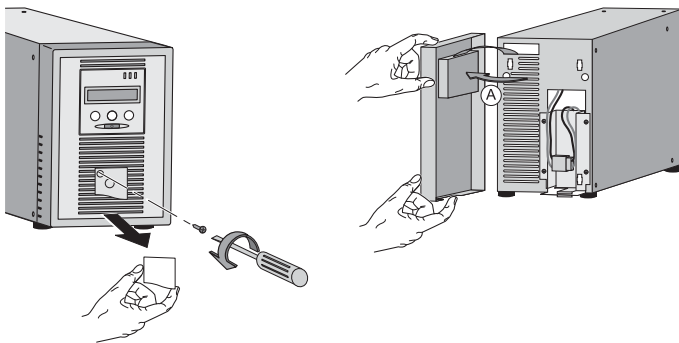

A - Put the front panel near the UPS.

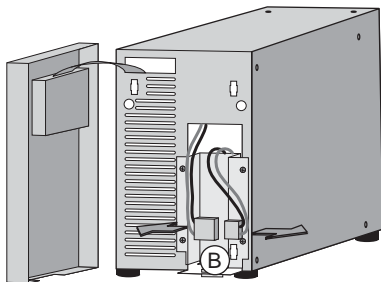

B - Disconnect the battery block by separating the two connectors (never pull on the wires).

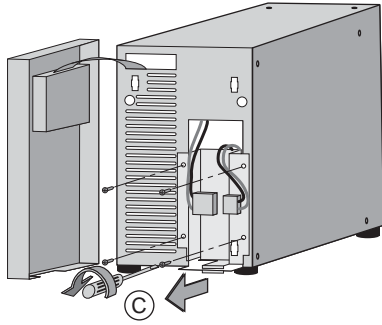

C - Remove the 4 fixing screws metal protection cover of the battery.

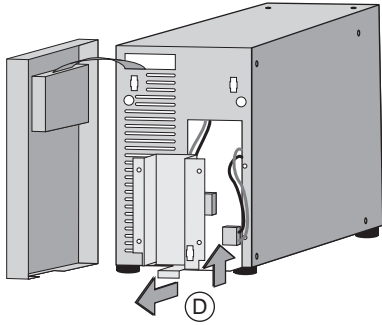

D - Remove the metal protection cover of the battery.

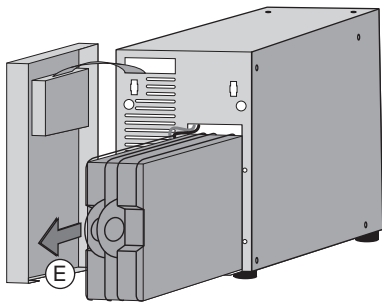

E - Pull the plastic tab to remove the battery block and replace it.

Mounting the new battery module

Carry out the above instructions in reverse order.



- ▶To ensure safety and high performance, use only batteries supplied by EATON.
- ▶Take care to firmly press together the two parts of the connector during remounting.

5.4 Training centre



To fully master operation of your EATON product and carry out level 1 servicing, see our complete range of technical training courses, available in both French and English.

For further information, please visit our website: www.eaton.com

6. Appendices

6.1 Technical specifications

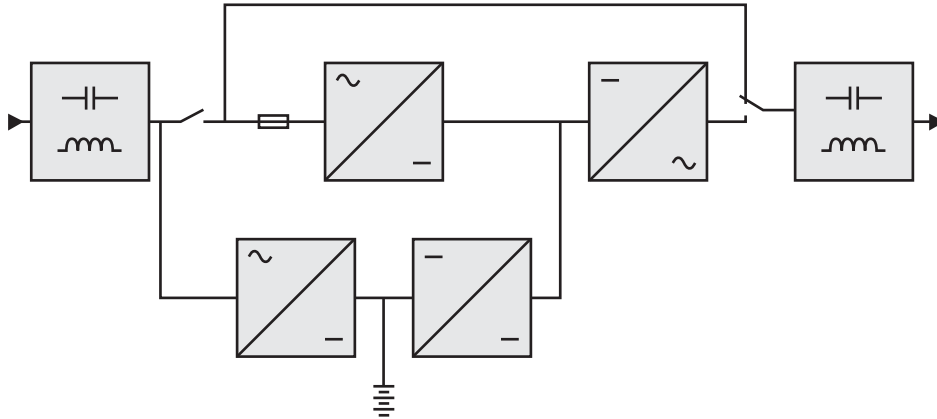

	EX 700	EX 1000 EX 1000 RT	EX 1500 EX 1500 RT	EX EXB ⁽¹⁾ EX EXB RT ⁽²⁾
Output power	700 VA / 630 W	1000 VA / 900 W ⁽³⁾	1500 VA / 1350 W ⁽⁴⁾	
AC input power	Single phase 100 / 120 / 140 V / 160 V / 184 V to 284 V ⁽⁵⁾ 50/60 Hz (autoselection) > 0.95			
Load output	Single phase 230 V ±3% ⁽⁶⁾ 50/60 Hz ±0.5% ⁽⁷⁾ < 4% for linear load, < 6% for nonlinear load 102% continuous, 130% 12 s, > 130% 2 s			
▶Current	3 A ⁽⁸⁾	4.3 A ⁽⁸⁾	6.5 A ⁽⁸⁾	
Battery	2x12 V - 7 Ah, sealed lead acid, maintenance free	3x12 V - 7 Ah, sealed lead acid, maintenance free	3x12 V - 9 Ah, sealed lead acid, maintenance free	Two 3x12 V - 9 Ah strings, sealed lead acid, maintenance free
Environment	▶Noise level < 38 dBA ▶Operating temperature range 0°C to 40°C ▶Relative humidity 20% to 90% (without condensation) ▶Leakage current < 1,1 mA ▶Storage temperature range -25°C to 40°C ▶Altitude 1000 m			
Standards and certification	▶Safety IEC/EN 62040-1-1, EN 60950-1 (RD) ▶Performance IEC/EN 62040-3 ▶EMC EN 50091-2/IEC 62040-2 class B, IEC 61000-4-2/-3/-4/-6-8/-11, IEC 61000-3-2/-3 ▶Markings CE, TÜV/GS, UL, cUL, CB report			

(1) EXB Module for EX 1000 and EX 1500.

(2) EXB Module for EX 1000 RT and EX 1500 RT.

(3) Output power is 900 W in standard configuration, and 800 W as soon as 1 EXB module is connected.

(4) Output power is 1350 W in standard configuration, and 1250 W as soon as 1 EXB module is connected.

(5) Values for 20% / 33% / 66% / 100% of UPS output.

(6) Adjustable from 200 V to 250 V using the **UPS Config** software.

(7) Frequency-converter mode is programmable using the **UPS Config** software.

(8) Nominal values given for 230 V output voltage.

6.2 Glossary

Bypass AC input	Bypass line from the AC-power source, controlled by the UPS, used to directly supply the load if an overload or a malfunction occurs on the UPS.
Backup time	Time during which the load can be supplied by the UPS operating on battery power.
Battery test	Internal UPS test to check battery status.
Equipments	Devices connected to the UPS output.
Excessive discharge	Battery discharge beyond the permissible limit, resulting in irreversible damage to the battery.
FlexPDU	Module with UPS outlets for installation in a bay. There are different modules with different types of outlets.
Frequency converter	Operating mode used to convert the AC-power frequency between the UPS input and output (50 Hz -> 60 Hz or 60 Hz -> 50 Hz).
HotSwap MBP	UPS manual-bypass module for maintenance. There are different modules with different types of outlets.
Low-battery warning	This is a battery-voltage level indicating that battery power is low and that the user must take action in light of the imminent break in the supply of power to the load.
Normal AC input	The AC-power line supplying the UPS under normal conditions.
Percent load	Ratio of the power effectively drawn by the load to the maximum output of the UPS.
Personalisation	It is possible to modify certain UPS parameters set in the factory. Certain UPS functions can also be modified by the UPS Config software or the LCD to better suit user needs.
Programmable outlets	These outlets can be automatically shut down during operation on battery power (shutdown time delays can be programmed with the UPS Config software). The UPS has two sets of two and one programmable outlets.
Start on battery power	The devices connected to the UPS can be started even when AC power is not available. The UPS operates only on battery power.
UPS	Uninterruptible Power System.
UPS ON/OFF controlled by software	This function enables or disables UPS ON/OFF control sequences by computer power management software.